



诚招全国代理商
Tel: 021-59217171

JQFM

剑桥阀业集团
Jianqiao Valve Industry Group

剑桥阀业集团有限公司
JIANQIAO VALVE INDUSTRY GROUP CO.,LTD.

地址：上海市奉贤区大叶公路1888弄158号
电话：021-59217171 59217272 59217373
传真：021-69106380

Http://www.jqfmc.com
E-mail: 1531698888@163.com



企业官网

微信公众号

版权归剑桥阀业集团有限公司所有。产品有专利，侵权行为应当追究法律责任。由于篇幅有限，本目录中未列出所有产品。如有需要，请联系我们索取。

All rights reserved. The violations of patent shall be investigated for legal responsibility. Due to space limitation, all products are not listed in this catalog. Please contact us for more information.

设计制作：中阀传媒

全方位管道系统阀门集成解决方案

Comprehensive Piping System Valve
Integration Solution

凝聚共识高度 创新改变未来

Consensus height
Innovation changes the future

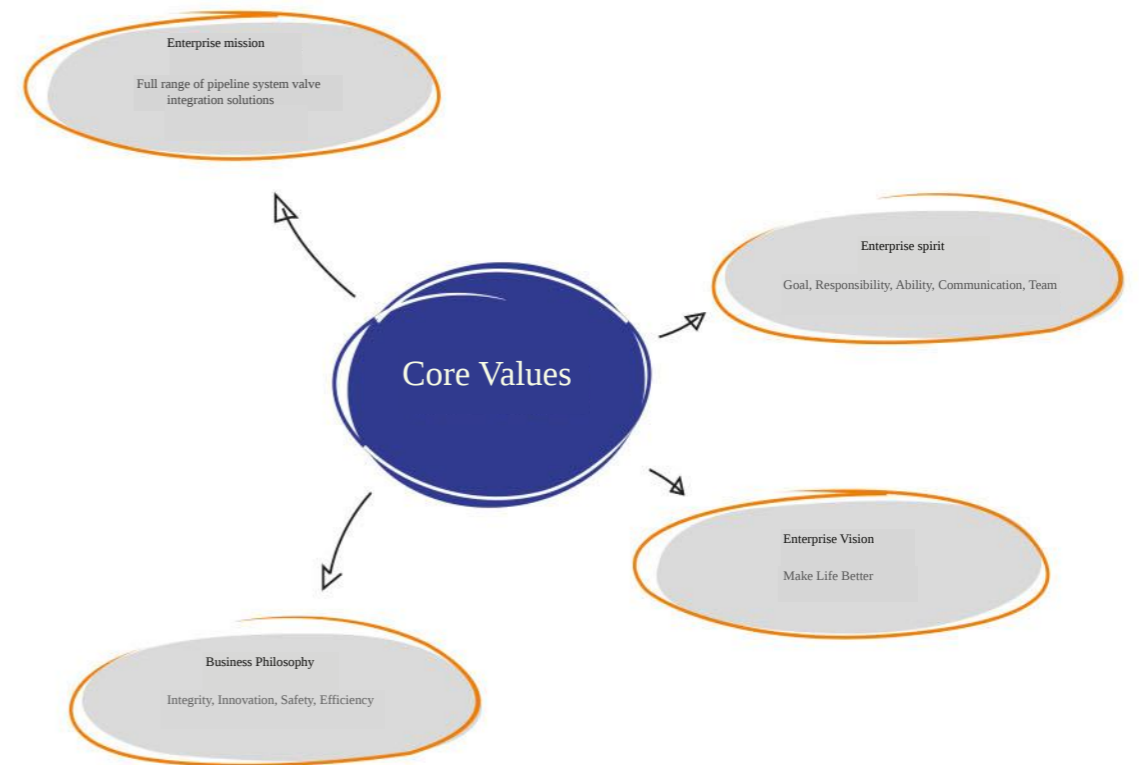

企业简介 Company Profile

Cambridge Valve Industry Group Co.

Ltd was founded in the early 1990s and is one of the professional valve manufacturers. After years of innovation and development, Cambridge products have been sold across China and overseas markets widely welcomed and praised by users from all walks of life and has been recognized as a National High-Tech Enterprise.

Cambridge Valve Industry Group Co. Ltd. headquartered at No. 158 Lane 1888 Daye Highway Fengxi and District Shanghai has a modern workshop of 12000 square meters and a R&D office building of over 4000 square meters. The group has two production bases located in the Economic and Technological Development Zone of Houshi City, Shanxi Province and Botou Development Zone, Cangzhou City, Hebei Province. The group's 80-million production base in the 2025 Industrial Park, Anxi County, Fujian Province has started construction. The group is strong in technology and well-equipped with 326 professional employees and 28 technical personnel with senior and intermediate titles. The group has advanced production lines and complete testing equipment. It improves product quality through scientific management, adopts computer network monitoring and management, and fully implements the ISO 9001 Quality Management System, ISO 14001 Environmental Management System and OHSAS 18001 Occupational Health and Safety Management System. It has obtained the Special Equipment Manufacturing License (TS for pressure pipelines), CCC Compulsory Product Certification, International UL and FM certifications, Shanghai Drinking Water Sanitation License, and has been recognized as a qualified supplier of Shanghai Quality Supervision and Inspection Technology Research Institute. It also holds the EU CE certification and China Fire Protection Network certification, becoming a qualified supplier for many domestic associations and large state-owned enterprises. The ball valves, hydraulic control valves, HVAC regulating valves and buried flange valves developed and produced by the company have been rated as national new products and won many awards, exerting a certain influence in the industry. They have been valued by the relevant industry departments of the Shanghai Municipal Government for several times and listed as a promoted brand by the Ministry of Housing and Urban-Rural Development.



The company has introduced 240 sets of large, medium and small advanced equipment, including compact hot forging valve production lines, wafer type, single clip, flange type, hard seal and soft seal butterfly valve production lines, and one production line each for natural gas flat valves and ball valves. It can produce high-quality valves meeting various national standards and various transmission modes. The leading products include eight categories: gate valves, globe valves, ball valves, butterfly valves, balance valves, regulating valves, check valves, hydraulic control valves, etc., dozens of varieties and thousands of specifications. The nominal diameter is 15mm-2000mm, the nominal pressure is 0.6MPa-32MPa, the applicable temperature is -80 - 550 °C, and the valve body materials include HT200, HT350, ZG25, SA-105, SA-182F9, SA-182F304, SA-182F316, etc. The products are suitable for central air conditioning, water supply and drainage, fire protection engineering, municipal engineering, food, metallurgy, mining, petroleum, chemical industry, natural gas, power stations, boilers, pipeline equipment, etc. We can also customize various non-standard products for customers.

全球水资源状况

global Water resources situation

72%

地球72%的面积被水所覆盖

97%

其中97%的水为咸海水，不适合饮用

70%

70%的淡水被锁在冰源下

1%

全球仅有1%的淡水可用

其中50%的淡水资源集中于6个国家
(巴西/俄罗斯/加拿大/印度尼西亚/中国和哥伦比亚)

33%

全球有33%的人口居住于“用水紧张”国家以
一个国家的淡水消耗率与可使用的淡水相比若该比例高于20%，则可定为高程度的用水紧张

Technological Innovation

剑桥阀门集团专注于阀门及产品的设计与生产
并致力于将全球先进的流体控制解决方案带给客户

Create more value for customers

剑桥阀门集团不仅仅是提供一个性能可靠的设备
更多是充分考虑适用性和经济及节能运行的解决方案



Provide users with solutions tailored to their needs



Production Control

The company possesses high-precision CNC machine tools and machining centers
Advanced equipment, excellent craftsmanship, and a strict, comprehensive quality management system
and gathers a team of specialized technical experts and high-caliber scientific personnel
making full use of new technologies, processes, and materials to ensure product stability and reliability



Advanced processes achieve perfect quality

Quality Assurance

公司配置了先进的检测设备以及完善的检测手段
建立了一支严格要求的品质管理队伍
实现了从原材料到生产全过程检测
产品及应用全过程的质量控制

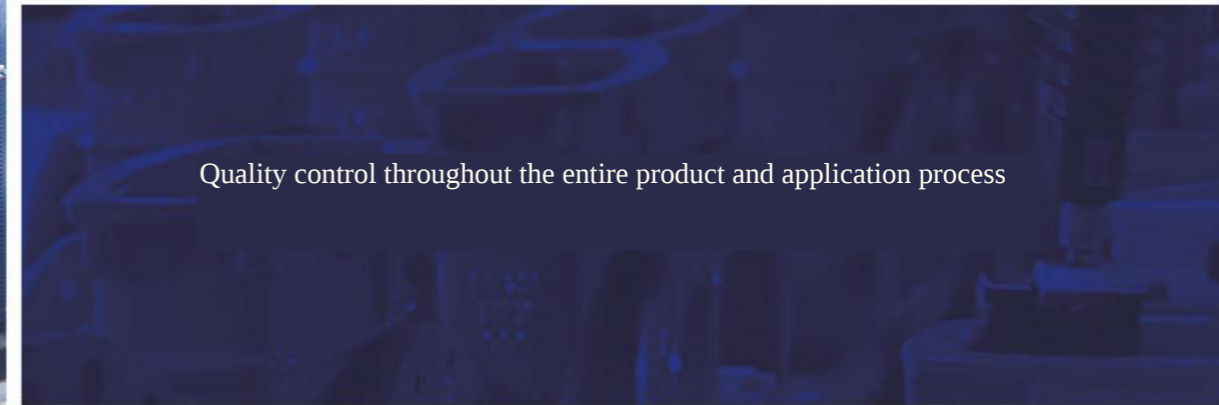

Product Applications

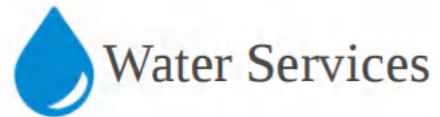

Water Services

Watertreatmentreferstophysicalandchemicalmeasures tobringwaterqualityto relevantstandards, anditspurposeistoimprove waterqualitytomeetspecified waterqualitystandards.



Construction

Structuresrefertoengineering buildingsotherthanhouses suchaswalls,roads,dams ,wellstunnelswatertowers ,bridgesandchimneys.



Environmental Protection

Itisageneraltermforallmeasures takenbyhumanbeings tosolveactualorpotential environmentalproblems,coordinatethe relationshipbetweenhumanbeingsandthe environmentandensuresustainable developmentofeconomyandsociety.



Pharmaceutical

Watertreatmentreferstophysicalandchemicalmeasures tomeetcertain guidelinesforwaterquality,its purposeistoimprove water qualitytomeetspecifiedstandards



Agriculture

Agricultureistheprimaryindustry.Thescienceofstudyingagricultureisagronomy. Theobjectofagricultural laborisliving animalsandplantsandtheproductsobtained aretheanimalsandplantsthemselves. Agricultureisthebasicindustrythatsupportstheconstructionanddevelopmentofthenationaleconomy.



Chemical Industry

Thechemicalindustrypenetratesall aspectsandisanindispensableand importantcomponentinthenationaleconomy. Itsdevelopmentfollowsthesustainabledevelopmentpathwhichhasimportantpractical significanceforhumaneconomicandsocial development.



Make life better

Quality Service



Dedication

Pre-sales Service
After-sales service
Lifetime service



Meticulous

Product design and manufacturing
Assembly and debugging throughout



Attentiveness

Regular follow-up with users
Guide maintenance and care
Training of maintenance personnel

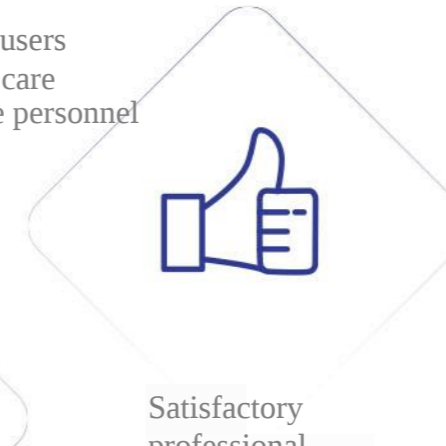

Satisfactory
professional
technicians
provide you
with full-
process
technical
support

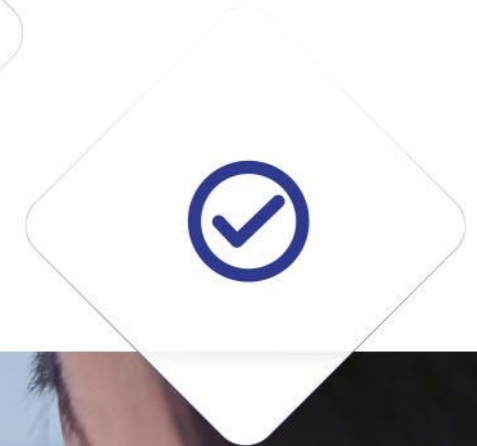

Assurance

Implement lifetime maintenance

Let you
Never a worry in the future

Customer satisfaction, we regard it as our life

Product Catalog

001	Soft Sealing Gate Valve	031	Diaphragm Type Multifunctional Pump Control Valve	051	Hydraulic Pneumatic Angle Type Quick Opening Sludge Discharge Valve	072	EDRV Series Dynamic Balance Electric Control Valve
006	Soft Seal Gate Valve	032	Diaphragm Type Remote Control Float Valve	052	Type H742 Pneumatic & Hydraulic Bottom Sludge Discharge Valve	074	EVR Series Dynamic Balance Valve
007	Protective Gate Valve	033	Diaphragm Type Adjustable Pressure Reducing and Stabilizing Valve	053	Type JM742X-1.0 Isolated Bottom Sludge Discharge Valve	075	Special Resilient Seated Gate Valve for Fire Protection
008	Wafer Type Butterfly Valve	034	Diaphragm Type Safety Relief & Sustaining Valve	054	SD44X Manual Sludge Discharge Valve	077	Special Butterfly Valve for Fire Protection
010	Flange Center Line Butterfly Valve	035	Diaphragm Type Electric Remote Control Valve	055	SCAR Compound Exhaust Valve	078	Grooved Gate Valve
012	Electric Manual Butterfly Valve	036	Piston Type Multifunctional Pump Control Valve	056	CARX Compound Exhaust Valve / CARX Compound Air Inlet and Exhaust Valve	079	Grooved Butterfly Valve
013	Special Ventilation Butterfly Valve	037	Low Resistance Backflow Preventer	057	P41X, P42X Quick Exhaust Valve / ARVX Micro Exhaust Valve	080	Fire Flow Switch / Fire Pressure Switch
015	Telescopic Flange Butterfly Valve	038	Hydraulically Controlled Slow Closing Check Butterfly Valve	058	Y-Strainer, Y-Type Telescopic Strainer	081	Swirl Preventer
016	Resilient Seat Eccentric Plug Valve	040	Low Resistance Slow Closing Check Valve	059	DF41, HS41 Backflow Preventer	082	Fire Ultrasonic Flowmeter / Electromagnetic Flowmeter
017	COLA/B/C Pipe Force Valve	041	Low Resistance Slow Closing Butterfly Check Valve	060	KPF Balancing Valve	083	Double Flange Expansion Joint
018	Eccentric Hemispherical Valve	042	Butterfly Type Cushion Check Valve	061	SP45F, SP15F Digital Lock Balancing Valve	084	Vacuum Breaker Valve
019	Piston Electric Regulating Valve	043	Silent Check Valve/Energy-Saving Silencing Check Valve	062	ZLF Self-Operated Balancing Valve	085	JR Type Metal Hose
020	Regulating Valve	044	Double Door Check Valve/Rubber Flap Check Valve	063	Self-Operated Balancing Valve	086	RFJD/S Type Single & Double Sphere Flexible Rubber Joint
021	Double Eccentric Hemispherical Valve	045	Slide Ball Check Valve/Low Resistance Ball Check Valve/Proportional	064	Self-Operated Differential Pressure Control Valve	087	Stainless Steel Valve
022	100X Remote Control Float Valve/106X Electric Remote Control Float Valve/200X Adjustable Pressure Reducing Valve/300X Slow Closing Check Valve	046	Pressure Reducing Valve	065	Static Flow Balancing Valve	089	HVAC Series
023	400X Flow Control Valve/500X Pressure Relief & Sustaining Valve	047	Pressure Reducing Valve	066	Dynamic Balance Electric Control Valve	092	Cambridge Mission and Commitment
024	600X Electric Control Valve/700X Pump Control Valve	048	DYH41X Three-Function Valve	067	Electric Valve		
025	800X Differential Pressure Bypass Balance Valve /900X Emergency Shutoff Valve	049	Suction Diffuser	069	Actuator / Control Valve		
026	CAMBRIDGEVALVE Series Backflow Preventer	050	Quick Opening Sludge Discharge Valve	070	Electric Control Valve		

Resilient Seated Gate Valve

Product Overview

Resilient seated gate valves are produced by our company by introducing high-tech European valve manufacturing technology. By utilizing the elastic deformation compensation effect of the fully rubber-covered gate plate, they achieve excellent sealing performance, overcoming the problems of poor sealing, water leakage and rusting common in ordinary gate valves. They can be widely used as regulating and shut-off devices on fluid pipelines in water supply, sewage treatment, construction, petroleum, chemical industry, food, medicine, textile, power, shipbuilding, metallurgy, energy systems and other fields.

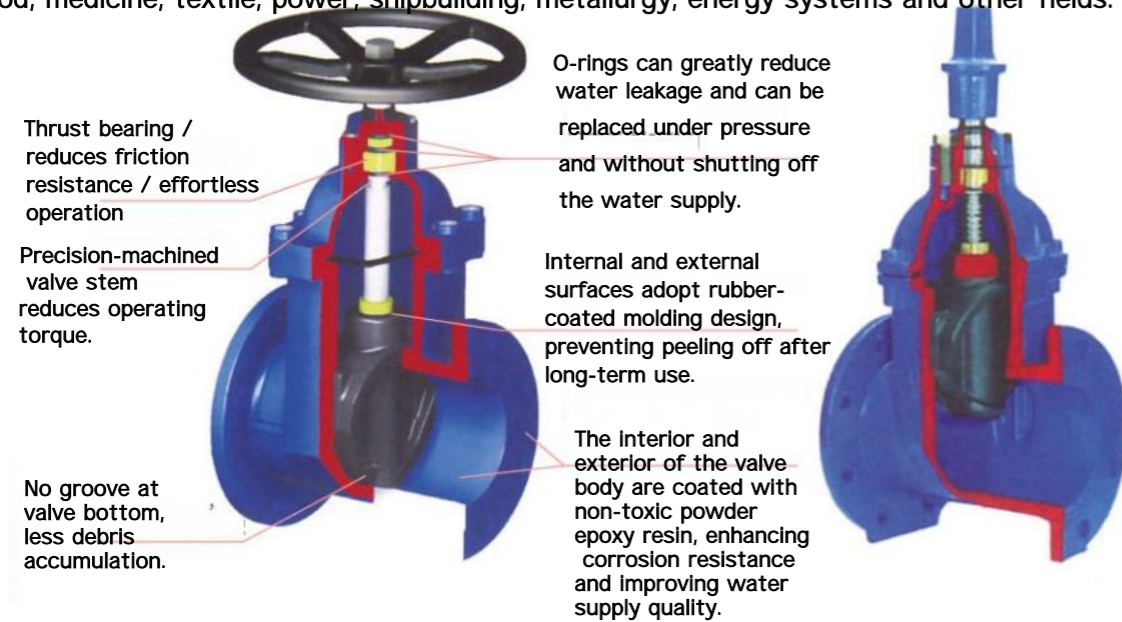

Light weight

Made of ductile iron with resin sand molding, high strength, small size, 20%~30% lighter than conventional gate valves, easy installation & maintenance.

Flat-bottom valve seat

Conventional gate valves usually have recessed seats, increasing flow resistance and easily trapping welding slag, stones, silt, etc., harming sealing and flow. Our resilient seated gate valves adopt flat-bottom full-bore straight design, same as straight pipe, less debris buildup, reliable sealing, unobstructed flow.

Full rubber-covered disc

Valve disc: fully encapsulated with high-quality rubber. Advanced vulcanization ensures precise dimensions, firm bonding to ductile iron, no peeling, good elastic memory.

Precision cast valve body

Precision-cast valve body ensures sealing without internal machining. Ductile iron gate frame, fully rubber-coated, with precise size, firm bonding, no peeling, good elastic memory and interchangeability.

Corrosion resistant

Valve body coated with powder epoxy, internals made of stainless steel or copper alloy, anti-corrosion and anti-rust, suitable for sewage systems.

Not easily broken

Traditional cast iron valves often break under impact or heavy pressure. Ductile iron body greatly reduces such risks.

O-ring seal

Three O-ring seals reduce friction, prevent leakage, and allow seal replacement without water shutdown.

Safe for drinking water

Non-toxic epoxy coating inside valve body, full rubber lining inside and out, no rust or corrosion, meets drinking water standards.

Resilient Seated Gate Valve

Non-rising Stem Resilient Seated Gate Valve

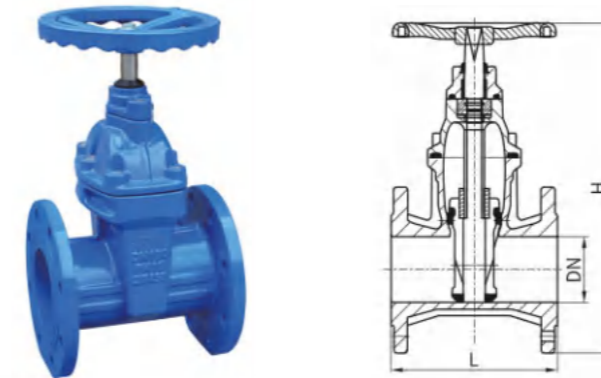

Non-rising Stem Resilient Seated Gate Valve

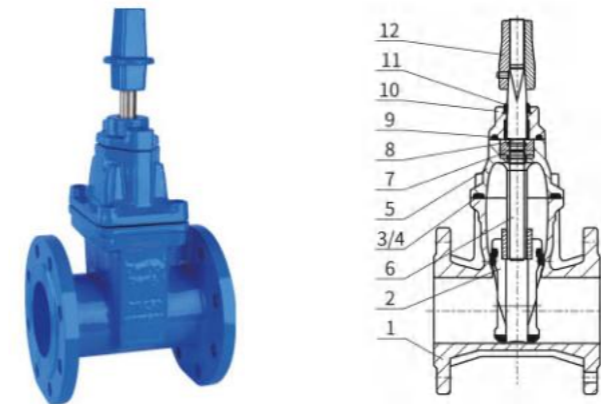

Main Parts Material

No.	Name	Material
1	Valve Body	Gray Cast Iron/Ductile Iron/Cast Steel
2	Gate	DI, EPDM/NBR External Coating
3	Hexagon Socket Head Cap Screw	Carburizing
4	Sealing Ring	NBR
5	Valve Cover	Gray Cast Iron/Ductile Iron
6	Valve Stem	Stainless Steel
7	O-ring Seal	NBR
8	Thrust Bearing	Tin Bronze
9	Bolt	Stainless Steel
10	Gland	Ductile Iron
11	Dust Cover	NBR
12	Handwheel Drive Cap	Gray Cast Iron

Typical Installation Diagram

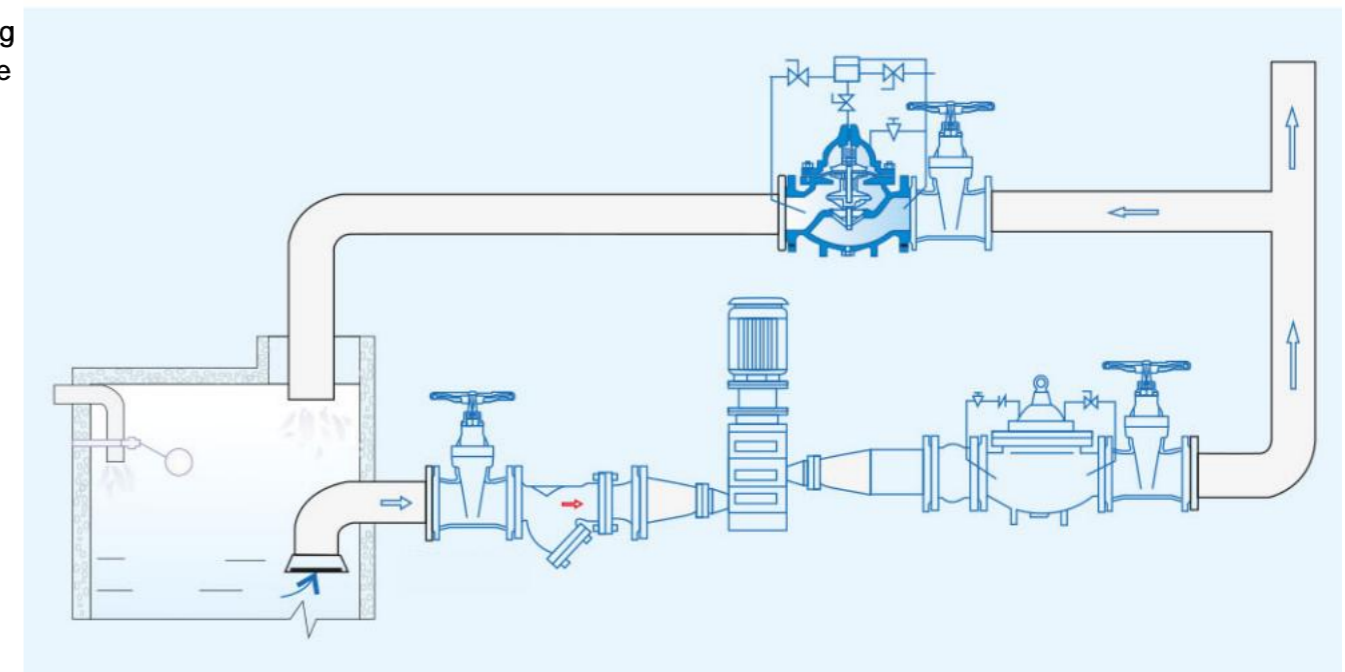

Resilient Seat Gate Valve

Rising Stem Resilient Seat Gate Valve

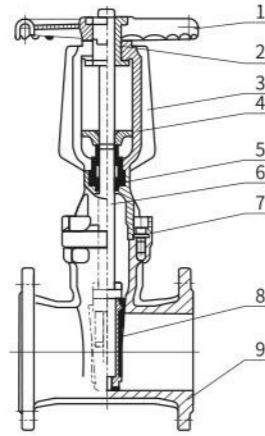

Main Component Materials

Serial Number	Name	Material
1	Handwheel	Ductile iron, cast steel
2	Stem nut	Copper alloy
3	Yoke	Gray iron, ductile iron, cast steel
4	Gland	Ductile iron, cast steel
5	Sealing ring	Nitrile rubber, EPDM
6	Valve stem	Stainless steel
7	Medium orifice gasket	Nitrile rubber, EPDM
8	Gate	Ductile iron coated with EPDM or nitrile rubber
9	Valve body	Gray iron, ductile iron, cast bronze

Resilient seated gate valve

Handwheel Type Resilient Seat Gate Valve

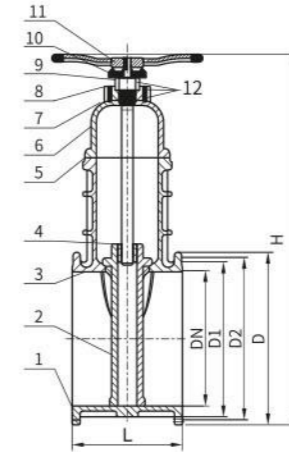

Main Component Materials

Serial Number	Name	Material
1	Valve Body	Ductile iron, cast steel
2	Gate	Ductile iron + EPDM or nitrile rubber
3	Stem	Stainless steel
4	Copper nut	Tin Bronze
5	Medium Port Gasket	Nitrile Rubber
6	Valve Cover	Gray Cast Iron, Ductile Cast Iron, Cast Steel
7	Thrust Bearing	Tin Bronze
8	Support Sleeve	Nylon 6
9	Bracket	Gray Cast Iron, Ductile Iron, Cast Steel
10	Dust Cover	Gray iron, ductile iron, cast steel
11	Handwheel	Malleable iron
12	Three-pass O-ring diagram	Nitrile rubber

bevel gear type resilient seated gate valve

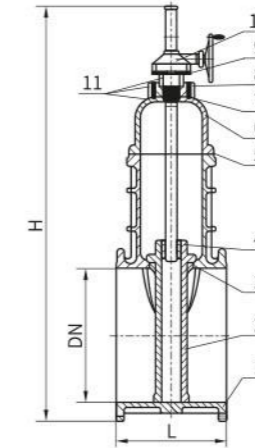

Main Component Materials

Serial Number	Name	Material
1	Handwheel	Ductile Iron, Cast Steel
2	Stem nut	Ductile iron + EPDM or NBR rubber
3	Yoke	Stainless steel
4	Gland	Tin bronze
5	Sealing ring	Nitrile rubber
6	Valve stem	Gray iron, ductile iron, cast steel
7	Middle gasket	Tin bronze
8	Gate slab	Nylon 6
9	Gate body	Gray iron, ductile iron, cast steel
10	Middle port gasket	Gray iron, ductile iron, cast steel
11	Gate	Nitrile rubber

Electric Resilient Seat Gate Valve

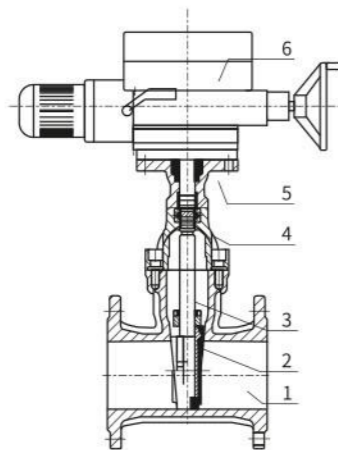

Main Component Materials

Serial Number	Name	Material
1	Valve Body	Ductile iron, cast steel
2	Gate	Ductile iron coated with EPDM or nitrile rubber
3	Stem	Stainless steel
4	Bonnet	Gray cast iron, ductile iron, cast steel
5	Bracket	Gray cast iron, ductile iron, cast steel
6	Electric actuator	Provided by supporting suppliers according to different electric actuators

Electric resilient seat gate valve

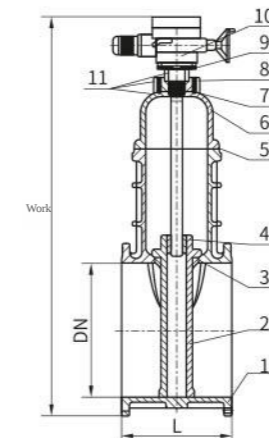

Main component materials

Serial number	Name	Material
1	Valve body	Ductile iron, cast steel
2	Gate	Ductile iron + EPDM or NBR rubber
3	Stem	Stainless steel
4	Copper Nut	Tin Bronze
5	Medium Port Gasket	Nitrile Rubber
6	Valve Cover	Gray Cast Iron, Ductile Iron, Cast Steel
7	Thrust bearing	Tin bronze
8	Support sleeve	Nylon 6
9	Bracket	Gray cast iron, ductile cast iron, cast steel
10	Electric actuator	-
11	Three O-rings	Nitrile rubber

Resilient Seat Gate Valve

Nominal Diameter - Test Torque Chart

Nominal Pressure: 1.6 MPa

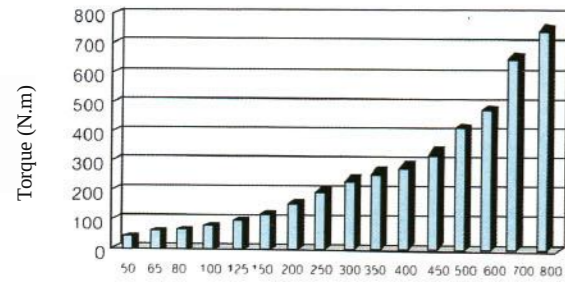

Nominal Diameter: DN (mm)

Nominal Pressure: 2.5 MPa

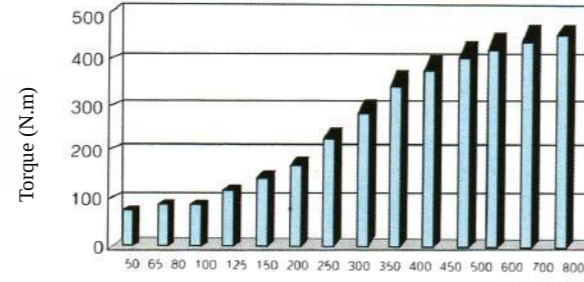

Nominal Diameter: DN (mm)

Technical Parameters

Nominal Pressure	Nominal Diameter	Operating Temperature	Applicable Medium	Flange Standard	Test Standard
1.0-2.5MPa	50~1200mm	0-80°C	Water, oil, gas, etc.	GB/T172416GB9113	GB13927AP598

Main Component Materials

DN	RVHX		RVCX		RRHX		RVEX	
	L	H	L	H	L	H	L	H
50	178	230	178	272	178	239	178	649
65	190	239	190	282	190	239	190	680
80	203	272	203	315	203	250	203	720
100	229	314	229	366	229	310	229	760
125	254	372	254	415	254	456	254	790
150	267	419	267	457	267	438	267	810
200	292	510	292	550	292	566	292	940
250	300	639	300	672	300	684	300	1065
300	356	725	356	767	356	786	356	1137
350	381	757	381	797	381	1047	381	1297
400	406	937	406	962	406	1097	406	1327
450	432	972	432	1002	432		432	1592
500	457	1145	457	1225	457		457	1603
600	508	1275	508	1360	508		508	1730
700	660		660		660		660	
800	720		720		720		720	
900	780		780		780		780	
1000	840		840		840		840	
1200	960		960		960		960	

Soft Seal Gate Valve

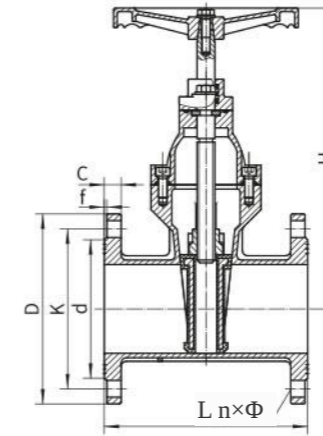

Product Description

The gate valve is one of the most widely used valves in various fluid transport engineering projects. Traditional gate valves commonly suffer from issues such as fluid leakage and severe internal corrosion. Currently, ordinary soft-sealed gate valves on the market are prone to external leakage at the valve stem shaft seal, and the sealing ring cannot be replaced without interrupting water flow and regardless of the valve's opening position.

The resilient seat gate valve, with its innovative structural design, stringent manufacturing techniques, and high-performance new materials, overcomes the drawbacks of traditional gate valves such as poor sealing, susceptibility to corrosion of internal parts (especially the gate), and rubber elasticity fatigue and aging. It offers reliable sealing performance, smooth operation, simple and convenient maintenance, and a long service life. Suitable for domestic water systems, water supply and drainage systems, wastewater treatment systems, chemical fluid transport systems, etc., it is used as a shut-off device in fluid pipelines across industries including construction, urban environmental protection, petrochemicals, pharmaceuticals, food, metallurgy, textiles, and electric power (not suitable for throttling).

Main Performance and Parameters

Working Pressure	PN10/PN16/PN25/150LB/10K/16K
Nominal Diameter	DN50~DN1000, 2"~40"
Operating temperature	0°C ~ 80°C
Applicable medium	Normal temperature water
Manufacturing standard	GB / JIS / ANSI / BSEN / ISO / DIN
Pressure Test	GB/T 13927-2008

Main Component Materials

Valve Body	Ductile Iron, Cast Steel
Valve Cover	Ductile iron, cast steel
Stem	Stainless steel, copper
Gate disc	EPDM / NBR
Packing	Graphite/PTFE/Rubber
Sealing ring	EPDM / NBR

Main external dimensions

Unit: mm

DN	L	H	D		K		d		C		f	n×Φ	
			PN10	PN16	PN10	PN16	PN10	PN16	PN10	PN16		PN10	PN16
50	178	240	165	165	125	125	99	99	19	19	3	4 times 19	4 times 19
65	190	270	185	185	145	145	118	118	19	19	3	4 times 19	4 times 19
80	203	285	200	200	160	160	132	132	19	19	3	8 times 19	8 times 19
100	229	310	220	220	180	180	156	156	19	19	3	8 by 19	8 by 19
125	254	375	250	250	210	210	184	184	19	19	3	8 by 13	8 by 19
150	267	420	285	285	240	240	211	211	19	19	3	8 by 23	8 by 23
200	292	530	340	340	295	295	266	266	20	20	3	8 by 23	12 by 23
250	330	640	395	405	350	355	319	319	22	22	3	12 by 23	12 by 28
300	356	730	445	460	400	410	370	370	24.5	24.5	4	12 by 23	12 by 28
350	381	850	505	520	460	470	429	429	24.5	26.5	4	16 by 23	16 by 28
400	406	950	565	580	515	525	480	480	24.5	28	4	16 by 28	16 by 31
450	432	1100	615	640	565	585	530	548	25.5	30	4	20 by 28	20 by 31
500	457	1200	670	715	620	650	582	609	26.5	31.5	4	20 by 28	20 by 34
600	508	1390	780	840	725	770	682	720	30	36	5	20 by 31	20 by 37
700	610	1550	895	910	840	840	794	794	32.5	39.5	5	24 by 31	24 by 37
800	660	1750	1015	1025	950	950	901	901	35	43	5	24 by 34	24 by 40
900	711	1950	1115	1125	1050	1050	1001	1001	37.5	46.5	5	28 by 34	28 by 40
1000	811	2170	1230	1255	1160	1170	1112	1112	40	50	5	28 by 37	28 × 43

Protection Gate Valve FBSF

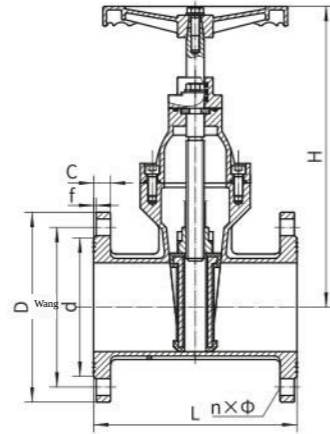

Product Description

The protection gate valve is one of the most widely used valves in various fluid transmission projects. Traditional gate valves commonly suffer from issues such as fluid leakage and severe internal corrosion. Currently, ordinary soft-sealed gate valves on the market are prone to external leakage at the valve stem seal, and the sealing ring cannot be replaced without shutting off the water and regardless of the opening position.

The resilient seat gate valve, with its innovative structural design, stringent manufacturing techniques, and high-performance new materials, overcomes the shortcomings of traditional gate valves such as poor sealing, susceptibility to corrosion of internal parts especially the gate, and rubber elasticity fatigue leading to aging. It offers reliable sealing performance, smooth operation, simple and convenient maintenance, and a long service life. Suitable for domestic water systems, water supply and drainage systems, wastewater treatment systems, chemical fluid transport systems, etc., it is used as a shut-off device in fluid pipelines across industries including construction, urban environmental protection, petrochemicals, pharmaceuticals, food, metallurgy, textiles, and power (not suitable for throttling).

Main Performance and Parameters

Working Pressure	PN10/PN16/PN25/150LB/10K/16K
Nominal Diameter	DN50~DN1000, 2"~40"
Operating temperature	0°C ~ 80°C
Suitable medium	Normal temperature water
Manufacturing standard	GB/JIS/ANSI/BS EN/ISO/DIN
Pressure Test	GB/T 13927-2008

Main Component Materials

Valve Body	Ductile Iron
Valve Cover	Ductile iron
Stem	Stainless steel, copper
Gate	Copper
Packing	Graphite/PTFE/Rubber
Sealing ring	EPDM/NBR

Main external dimensions

Unit: mm

DN	L	H	D		K		d		C		f	n×Φ	
			PN10	PN16	PN10	PN16	PN10	PN16	PN10	PN16		PN10	PN16
50	178	240	165	165	125	125	99	99	19	19	3	4×19	4 by 19
65	190	270	185	185	145	145	118	118	19	19	3	4 by 19	4 by 19
80	203	285	200	200	160	160	132	132	19	19	3	8 by 19	8 by 19
100	229	310	220	220	180	180	156	156	19	19	3	8 by 19	8 by 19
125	254	375	250	250	210	210	184	184	19	19	3	8 by 19	8 by 19
150	267	420	285	285	240	240	211	211	19	19	3	8 by 23	8 by 23
200	292	530	340	340	295	295	266	266	20	20	3	8 by 23	12 × 23
250	330	640	395	405	350	355	319	319	22	22	3	12 by 23	12 × 28
300	356	730	445	460	400	410	370	370	24.5	24.5	4	12 by 23	12 × 28
350	381	850	505	520	460	470	429	429	24.5	26.5	4	16 by 23	16 × 28
400	406	950	565	580	515	525	480	480	24.5	28	4	16 by 28	16 × 31
450	432	1100	615	640	565	585	530	548	25.5	30	4	20 by 28	20 by 31
500	457	1200	670	715	620	650	582	609	26.5	31.5	4	20 by 28	20 by 34
600	508	1390	780	840	725	770	682	720	30	36	5	20 by 31	20 by 37
700	610	1550	895	910	840	840	794	794	32.5	39.5	5	24 by 31	24 by 37
800	660	1750	1015	1025	950	950	901	901	35	43	5	24×34	24×40
900	711	1950	1115	1125	1050	1050	1001	1001	37.5	46.5	5	28×34	28×40
1000	811	2170	1230	1255	1160	1170	1112	1112	40	50	5	28×37	28 × 43

Wafer-type Butterfly Valve

Product Overview

The D71/371X wafer butterfly valve adopts a centerline design. Its main structure consists of components such as the valve body, disc, seat, stem, and transmission operating mechanism. The seat features a removable construction and can be made from materials suitable for high temperature, low temperature, corrosion resistance, light resistance, and aging resistance, depending on the physical and chemical properties of the medium. It is widely applicable in fluid pipelines for water supply and drainage, sewage, construction, air conditioning, petroleum, chemical, food, pharmaceutical, light textile, papermaking, hydropower, shipping, metallurgy, and energy systems, serving as a regulating and shut-off device.

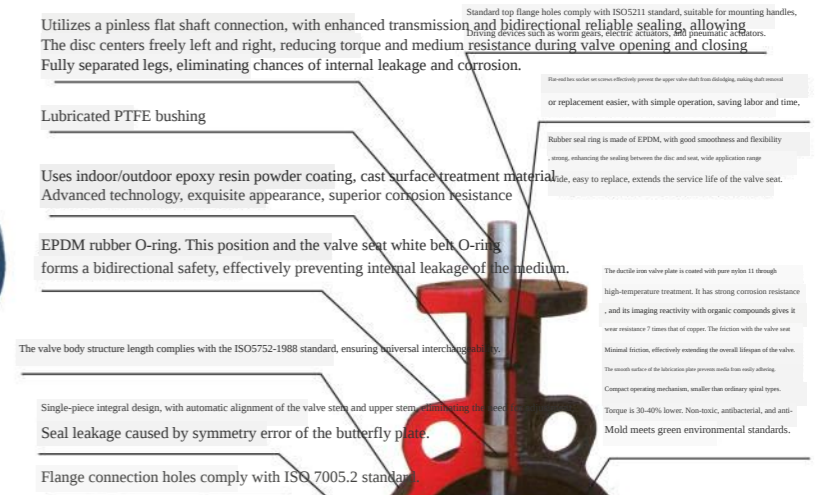

Technical parameters

Shell test pressure (MPa)	1.5MPa, 2.4MPa, 3.0MPa
Sealing test pressure (MPa)	1.1MPa, 1.76MPa, 2.2MPa
Exterior painting	Epoxy polyester coating, nylon 11, baking paint, covering epoxy resin
Drive type	Handle, worm gear, electric, pneumatic
Applicable Temperature	-35°C to 350°C
Applicable Medium	Water, salt, acid, alkali, natural gas, air, alcohols, oils, etc.

Main Component Materials

Name	Material	Applicable Specifications
Valve Body	Ductile Iron	50mm-600mm
	Gray cast iron	50mm-600mm
	Cast steel	50mm-300mm
	Stainless steel	50mm-300mm
Valve plate	Aluminum	50mm-300mm
	Stainless steel CF8	50mm-600mm
	Stainless Steel CF8M	50mm-600mm
	Nickel-Phosphorus Plated Ductile Iron	50mm-600mm
Valve Stem	Nylon-Coated Ductile Iron	50mm-600mm
	Aluminum Bronze	50mm-600mm
	Stainless Steel 410	50mm-600mm
	Stainless Steel 316	50mm-600mm
Valve Seat	Stainless Steel 304	50mm-600mm
	Nickel-Phosphorus Plated Carbon Steel	50mm-600mm
	Nitrile Rubber NBR	50mm-600mm
	Ethylene Propylene Diene Monomer EPDM	50mm-600mm
Valve Seat	Fluoroelastomer VITON	50mm-600mm
	Silicone Rubber SEP	50mm-600mm
	Heat-Resistant EPDM	50mm-600mm
	Abrasion-Resistant EPDM	50mm-600mm
	PTEE	50mm-600mm

Wafer Type Butterfly Valve

Seal Applicable Media, Temperature

Sealing Pair Material	Applicable Temperature	Media Type and Applicability													Prominent Features
		Freshwater	Seawater	Salts	Strong Alkali	Weak Alkali	Strong acid	Weak acid	Natural gas	Alcohols	Air	Steam	Oil pan	Food	
Nitrile	-12°C - 82°C	A	A	A	B	A	D	B	A	C	A	D	A	B	Oil-resistant
EPDM	-35°C - 135°C	A	A	A	A	A	C	A	B	B	A	A	C	A	Aging-resistant
Corrosion-resistant EPDM	-35°C - 160°C	A	A	A	A	A	A	A	B	B	A	A	C	A	Corrosion-resistant, aging-resistant
Fluoroelastomer	-23°C - 135°C	A	A	A	A	A	C	A	A	C	A	A	A	A	High-temperature resistant, corrosion-resistant
Polytetrafluoroethylene	-10°C - 150°C	A	A	A	C	A	A	A	A	A	A	A	A	A	Corrosion-resistant, high-temperature resistant
Ductile Iron Plating	-30°C - 350°C	B	D	C	D	C	D	C	B	A	B	A	A	C	Heat-Resistant
Ductile iron with Nylon Coating	-30°C - 100°C	A	A	A	A	A	D	A	A	C	A	D	A	A	Corrosion-Resistant, Wear-Resistant, Friction-Reducing
Aluminum Bronze	-273°C - 232°C	A	B	C	D	C	D	B	A	A	A	A	A	C	Heat-resistant, corrosion-resistant
Stainless steel	-268°C - 316°C	A	B	C	C	B	C	A	A	A	A	A	A	A	High-temperature resistant, corrosion-resistant

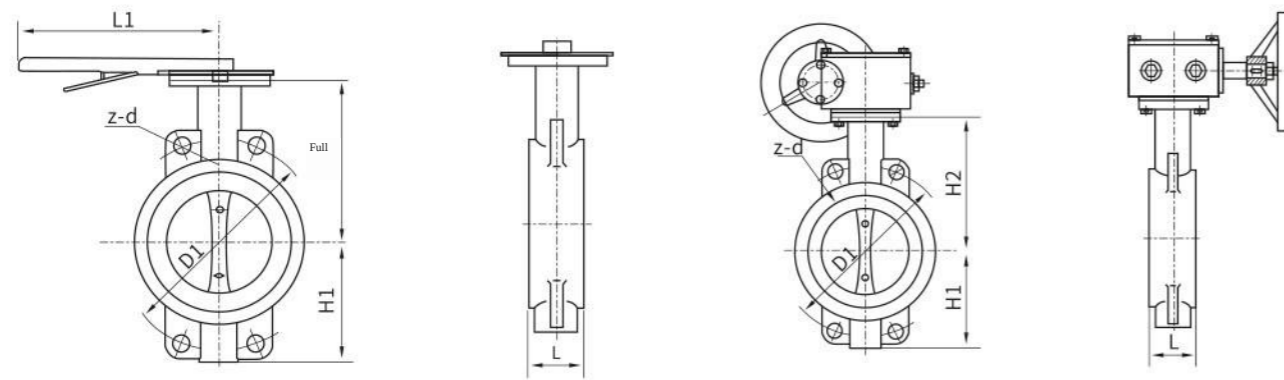

Main external connection dimensions (handle)

(Worm gear)

Unit: mm

DN	L	L1	D1	H2	H1	z-d	n-M
50	45	250	125	88	64	4-φ18	4-M16
65	51	250	145	115	80	4-φ18	4-M16
80	52	250	160	130	85	4-φ18	4-M16
100	58	250	180	150	110	4-φ18	4-M16
125	58	280	210	170	127	4-φ18	4-M16
150	58	280	240	185	140	4-φ22	4-M20
200	65	280	295	215	175	4-φ22	4-M20

DN	L	D1	H2	H1	z-d	n-M
150	58	240	185	140	4-φ22	8-M20
200	65	295	215	175	4-φ22	8-M20
250	70	350	245	206	4-φ22	12-M20
300	80	400	285	242	4-φ22	16-M20
350	85	460	305	265	4-φ22	16-M20
400	95	515	357	308	4-φ22	16-M20
450	125	565	385	330	4-φ26	20-M24
500	139	620	450	350	4-φ26	20-M24
600	159	725	510	410	4-φ30	20-M27
700	168	840	550	480	4-F30	24-M27

Flange Centerline Butterfly Valve

Product Overview

The D341X flange centerline butterfly valve features a double eccentric soft-sealed structure, with characteristics such as compact size, light weight, and good bidirectional sealing performance. It is a valve that opens and closes by rotating the disc 90°, suitable not only for cutting off media but also for regulating media flow. Butterfly valves for above-ground use can be operated by handwheel; when required by the user, they can be switched to electric or pneumatic operation. Special buried butterfly valves are operated by a lever. Suitable for circulating water supply and drainage on various pipelines.

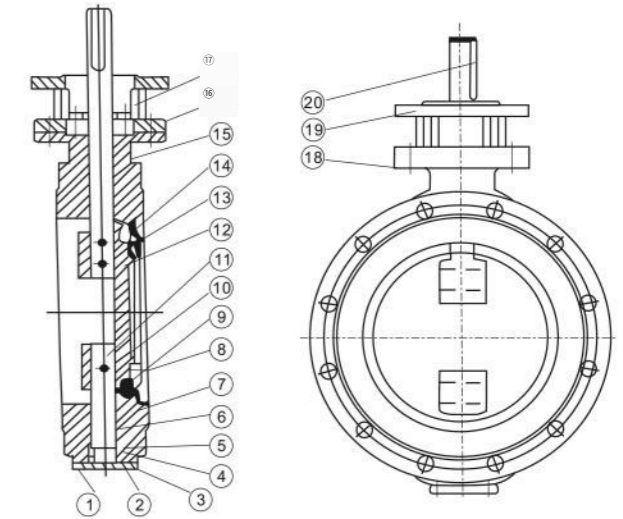

Technical Parameters

Material Used: Ductile Iron, Carbon Steel
 Size range: DN50mm to DN4000mm
 Pressure rating: 1.0MPa to 1.6MPa
 Temperature range: -10°C to 120°C
 Applicable media: clean water, wastewater

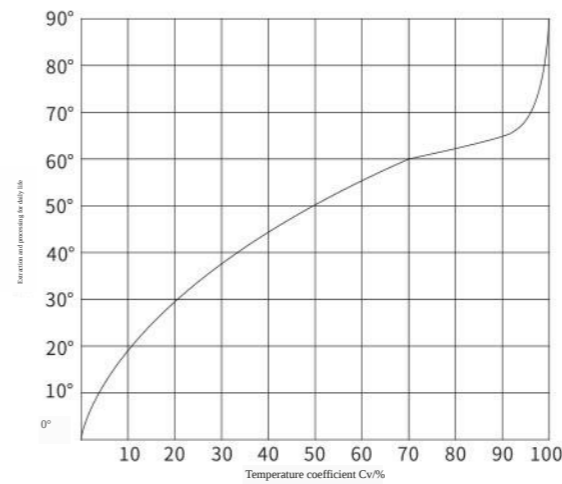

Main Component Materials

Serial Number	Name	Material	Standard
1	Bolt	Carbon Steel	AISI 1045
2	O-ring	Nitrile rubber	NBR
3	Lower end cap	Ductile iron	ASTM A536
4	Shim	Stainless steel	AISI420
5	Open-loop	Stainless steel	AISI420
6	Shaft sleeve	Aluminum bronze	ASTM C61900
7	Valve body	Ductile iron	ASTM A536
8	Bolt	Carbon steel	AISI 1045
9	Valve disc seal ring	Nitrile rubber	NBR
10	Valve disc	Ductile iron	ASTM A536
11	Lower rotating shaft	Stainless steel	AISI 420
12	Upper rotating shaft	Stainless steel	AISI 420
13	Taper pin	Stainless Steel	AISI 420
14	Compression Ring	Ductile Iron	ASTM A536
15	O-Ring	Nitrile Rubber	NBR
16	Gland Packing	Ductile iron	ASTM A536
17	Stud Bolt	Carbon Steel	AISI 1045
18	Bolt	Carbon Steel	AISI 1045
19	Connection Bracket	Ductile Iron	ASTM A536
20	Plain Flat Key	Carbon Steel	AISI 1045

Flanged Centerline Butterfly Valve

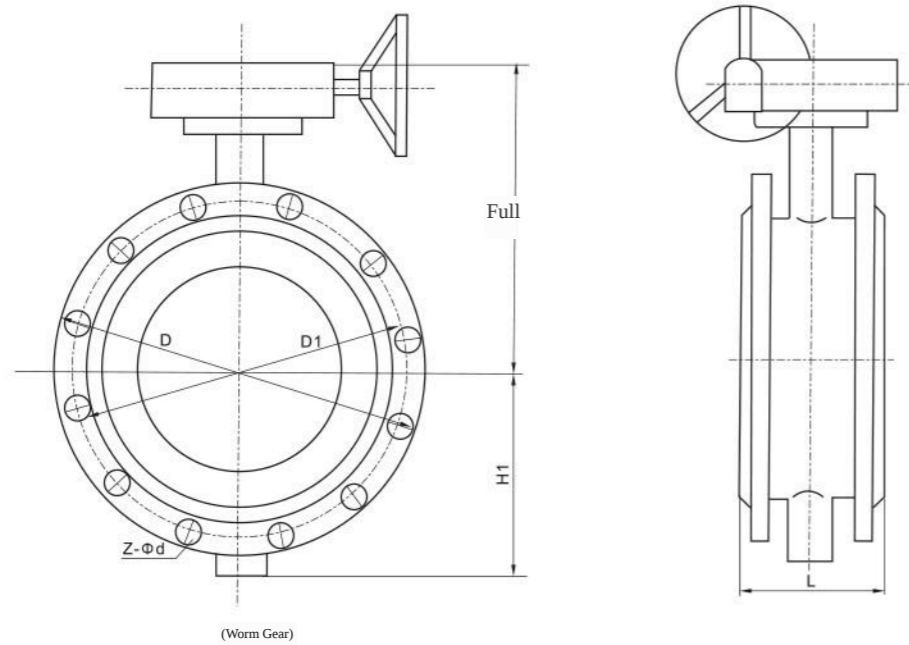

Main External Connection Dimensions

Unit: mm

DN	L	H1	H2	1.0 MPa			1.6 MPa		
				D	D1	Z-Φd	D	D1	Z-Φd
50	108	202	77	165	125	4-18	165	125	4-18
65	112	213	93	185	145	4-18	185	145	4-18
80	114	221	100	200	160	8-18	200	160	8-18
100	127	234	113	220	180	8-18	220	180	8-18
125	140	253	123	250	210	8-18	250	210	8-18
150	140	269	193	285	240	8-22	285	240	8-22
200	152	316	172	340	295	8-22	340	295	12-22
250	165	358	202	395	355	12-22	405	355	12-26
300	178	384	218	445	410	12-22	460	410	12-26
350	190	439	253	505	470	16-22	520	470	16-26
400	216	500	300	565	525	16-26	580	525	16-30
450	222	528	328	615	585	20-26	640	585	20-30
500	229	552	352	670	650	20-26	715	650	20-33
600	267	669	397	780	770	20-30	840	770	20-36
700	292	745	498	895	840	24-30	910	840	24-36
800	318	803	571	1015	950	24-33	1025	950	24-40
900	510	880	615	1115	1050	28-33	1125	1050	28-40
1000	550	935	705	1230	1160	28-36	1255	1170	28-43
1200	630	1067	827	1455	1380	32-39	1485	1390	32-49
1400	710	1210	1010	1675	1590	36-43	1685	1590	32-48
1600	790	1340	1140	1915	1820	40-49	1930	1820	36-55
1800	870	1460	1360	2115	2020	44-49	2130	2020	40-55
2000	950	1660	1485	2325	2230	48-49	2345	2230	44-60

Manual/Electric Dual-Purpose Butterfly Valve

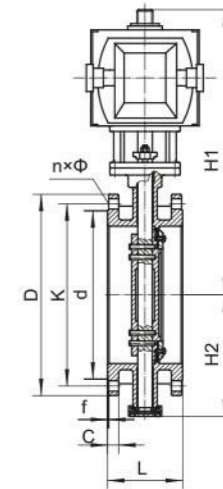

Main Performance and Parameters

Nominal Pressure		PN10	PN16	
Test pressure	Shell strength	1.5	2.4	MPa
	Liquid, high-pressure sealing	1.1	1.76	
	Gas low-pressure sealing	0.6	0.6	
Medium temperature		-10~80°C		
Applicable Medium		Water, etc.		

Main Component Materials

Valve Body	Ductile Iron
Butterfly plate	Ductile iron
Valve stem	Chrome stainless steel
Valve seat	Ductile iron, stainless steel
Seal ring	Nitrile rubber, EPDM rubber
Drive method	Worm gear, pneumatic, electric

Main overall dimensions

Unit: mm

DN	L	H1	H2	D		K		d		C		f	n×Φ	
				PN10	PN16	PN10	PN16	PN10	PN16	PN10	PN16		PN10	PN16
50	108	155	80	165	165	125	125	99	99	19	19	3	4×19	4×19
65	112	155	80	185	185	145	145	118	118	19	19	3	4×19	4×19
80	114	173	97	200	200	160	160	132	132	19	19	3	8×19	8 by 19
100	127	220	110	220	220	180	180	156	156	19	19	3	8 by 19	8 by 19
125	140	255	125	250	250	210	210	184	184	19	19	3	8 by 19	8 by 19
150	140	258	143	285	285	240	240	211	211	19	19	3	8 by 23	8 by 23
200	152	310	170	340	340	295	295	266	266	20	20	3	8 by 23	12 by 23
250	165	355	200	395	405	350	355	319	319	22	22	3	12 by 23	12 by 28
300	178	380	225	445	460	400	410	370	370	24.5	24.5	4	12 by 23	12×28
350	190	422	253	505	520	460	470	429	429	24.5	26.5	4	16×23	16×28
400	216	486	284	565	580	515	525	480	480	24.5	28	4	16×28	16×31
450	222	497	308	615	640	565	585	530	548	25.5	30	4	20×28	20 by 31
500	229	560	335	670	715	620	650	582	609	26.5	31.5	4	20 by 28	20 by 34
600	267	715	390	780	840	725	770	682	720	30	36	5	20 by 31	20 by 37
700	292	782	483	895	910	840	840	794	794	32.5	39.5	5	24 by 31	24 by 37
800	318	882	543	1015	1025	950	950	901	901	35	43	5	24 by 34	24 by 40
900	330	925	606	1115	1125	1050	1050	1001	1001	37.5	46.5	5	28 by 34	28 by 40
1000	410	1000	655	1230	1255	1160	1170	1112	1112	40	50	5	28 by 37	28 by 43
1200	470	1087	778	1455	1485	1380	1390	1328	1328	45	57	5	32 × 40	32 × 49
1400	530	1350	912	1675	1685	1590	1590	1530	1530	45	60	5	36 × 43	36 × 49
1600	600	1475	1032	1915	1930	1820	1820	1750	1750	49	65	5	40 × 49	40 × 56
1800	670	1670	1154	2115	2130	2020	2020	1950	1950	52	70	5	44 × 49	44 × 56
2000	760	1780	1295	2325	2345	2230	2230	2150	2150	55	75	5	48 × 49	48 × 62
2200	800	2180	1480	2550	2555	2440	2440	2370	2360	58	70	5	52 × 56	52 × 62
2250	800	2210	1510	2600	2605	2490	2490	2420	2410	60	70	5	52 × 56	52 by 62
2400	850	2350	1590	2760	-	2650	-	2570	-	65	-	6	56 × 56	-
2600	850	-	-	2960	-	2850	-	2780	-	70	-	6	60 by 56	-
2800	850	-	-	3200	-	3080	-	-	-	75	-	6	60 by 60	-
3000	900	-	-	3400	-	3280	-	-	-	80	-	6	64 by 60	-

Ventilation Special Butterfly Valve

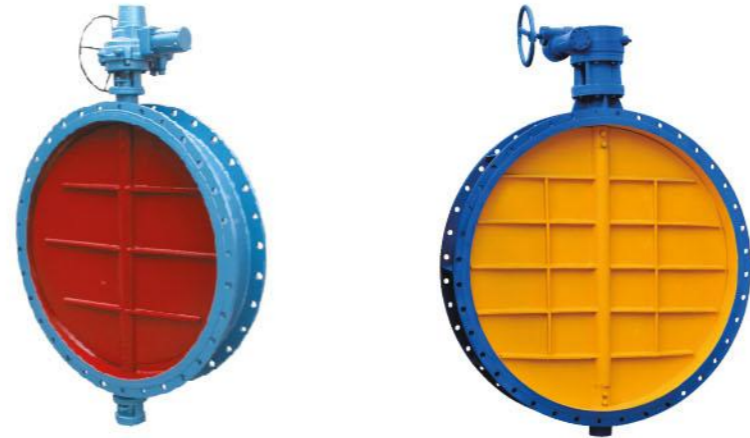

The flue duct butterfly valve uses a sealing ring machined from the same material as the valve body. Its applicable temperature depends on the material selected for the valve body, with a general nominal pressure less than 0.6MPa. It is typically used in power plants, metallurgy, environmental protection, and other fields for cutting off and regulating hot air media.

Uses and Features

This butterfly valve uses a sealing ring machined from the same material as the valve body and is operated by electric or pneumatic rotation. Its applicable temperature depends on the material selected for the valve body, with a nominal pressure of ≤ 0.6 MPa. It is generally suitable for pipelines in industries such as industrial, metallurgy, and environmental protection for regulating ventilation media flow.

Its main features are:

1. Novel and rational design, unique structure, light weight, and quick opening/closing.
2. Low torque, easy operation, labor-saving and agile.
3. Suitable materials are used to meet different medium temperatures (low, medium, high) and corrosive media.

Standards Adopted

Design Standard: GB/T12238

Flange Connection Dimensions: GB/T9113

Structural Length: GB/T12221

Pressure Test: GB/T13927, JB/T9092

Main Performance Specifications

Nominal Diameter	DN (mm)	100-4000			
Nominal Pressure	PN (MPa)	0.05	0.10	0.25	0.6
Test Pressure	Strength Test	0.075	0.15	0.375	0.9
	Sealing Test	Enclosed Type	0.055	0.11	0.275
		Non-Enclosed Type	$\leq 1.5\%$ leakage		
Applicable media		Coal gas, dust-laden gas, flue gas, etc.			
Drive type		Manual, worm gear, pneumatic, electric actuation			

Main component materials

Part Name	Material
Valve Body	Q235A, 16Mn Steel, Stainless Steel
Butterfly Plate	Q235A, 16Mn Steel, Stainless Steel
Sealing ring	Stainless steel
Valve stem	Stainless steel
Packing	Flexible graphite

Ventilation Special Butterfly Valve

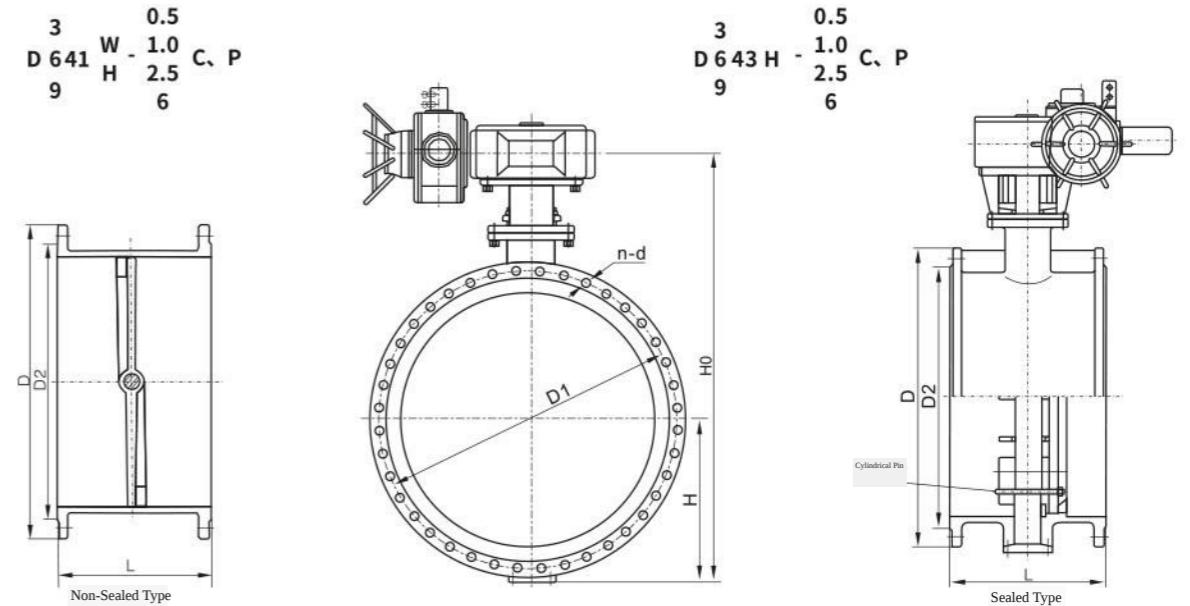

Main Connection Dimensions

Nominal Diameter DN (mm)	L	H	H0	0.05-0.1 MPa				0.25 MPa				0.6 MPa			
				D	D1	D2	n-d	D	D1	D2	n-d	D	D1	D2	n-d
100	127	105	486	210	170	144	4-18	210	170	144	4-18	210	170	144	4-18
125	140	120	516	240	200	174	8-18	240	200	174	8-18	240	200	174	8-18
150	140	132	541	265	225	199	8-18	265	225	199	8-18	265	225	199	8-18
200	152	160	779	320	280	254	8-18	320	280	254	8-18	320	280	254	8-18
250	165	187	836	375	335	309	12-18	375	335	309	12-18	375	335	309	12-18
300	178	220	901	440	395	363	12-22	440	395	363	12-23	440	395	363	12-23
350	180	245	954	490	445	413	12-22	490	445	413	12-23	490	445	413	12-23
400	200	270	1003	540	495	463	16-22	540	495	463	16-23	540	495	463	16-23
450	200	297	1058	595	550	518	16-22	595	550	518	16-23	595	550	518	16-23
500	220	322	1111	645	600	568	20-22	645	600	568	20-23	645	600	568	20-23
600	220	377	1233	755	705	667	20-26	755	705	667	20-26	755	705	667	20-26
700	240	430	1338	860	810	772	24-26	860	810	772	24-26	860	810	772	24-26
800	240	487	1452	975	920	878	24-30	975	920	878	24-30	975	920	878	24-30
900	260	537	1588	1075	1020	978	24-30	1075	1020	978	24-30	1075	1020	978	24-30
1000	260	587	1689	1175	1120	1078	28-30	1175	1120	1078	28-30	1175	1120	1078	28-30
1200	280	702	1938	1375	1320	1280	32-30	1375	1320	1280	32-30	1405	1340	1295	32-33
1400	300	782	2670	1575	1520	1480	36-30	1575	1520	1480	36-30	1630	1560	1510	36-36
1600	320	895	2810	1790	1730	1690	40-30	1790	1730	1690	40-30	1830	1760	1710	40-36
1800	340	995	3020	1990	1930	1890	44-30	1990	1930	1890	44-30	2045	1970	1918	44-40
2000	360	1095	3220	2190	2130	2090	48-30	2190	2130	2090	48-30	2265	2180	2125	48-42
2200	380	1200	3430	2405	2340	2295	52-33	2405	2340	2295	52-33	2475	2390	2335	52-42
2400	400	1310	3650	2605	2540	2495	56-33	2605	2540	2495	56-33	2685	2600	2545	56-42
2600	420	1420	3920	2805	2740	2695	60-33	2805	2740	2695	60-33	2905	2810	2750	60-48
2800	440	1530	4140	3030	2960	2910	64-36	3030	2960	2910	64-36	3115	3020	2960	64-48
3000	460	1640	4360	3230	3160	3110	68-36	3230	3160	3110	68-36	3315	3220	3160	68-48
3200	480	1760	4620	3430	3360	3310	72-36	3430	3360	3310	72-36	3525	3430	3360	72-48
3400	500	1870	4840	3630	3560	3510	76-36	3630	3560	3510	76-36	3735	3640	3560	76-48
3600	520	1980	5060	3840	3770	3720	80-36	3840	3770	3720	80-36	3970	3860	3720	80-56
3800	540	2120	5400	4045	3970	3920	80-39	4045	3970	3920	80-39	4180	4070	3970	80-62
4000	560	2230	5620	4245	4170	4120	84-39	4245	4170	4120	84-39	4380	4270	4170	84-62

Note: Flange connections comply with EN, JIS, DIN, GB standards,
When * ≤ 24 , also conforms to ASME B16.5 standard
When * > 24 , conforms to ASME B16.47-A/B standard

Expansion Flange Butterfly Valve S

Product Overview

The SD341X expansion flange butterfly valve integrates two functions: pipeline expansion joint and butterfly valve. It not only acts as a throttle but also eliminates internal forces caused by temperature differences, providing expansion and contraction capabilities. This valve features a novel design, unique structure, compact size, and light weight. It operates easily and effortlessly, opens and closes quickly, allows adjustment and replacement of sealing parts, offers reliable sealing performance, low flow resistance, and energy efficiency. Suitable for temperatures $\leq 80^{\circ}\text{C}$, it is used in power, water supply, and drainage systems to regulate flow and shut off media, with the ability to compensate for pipeline thermal expansion and contraction.

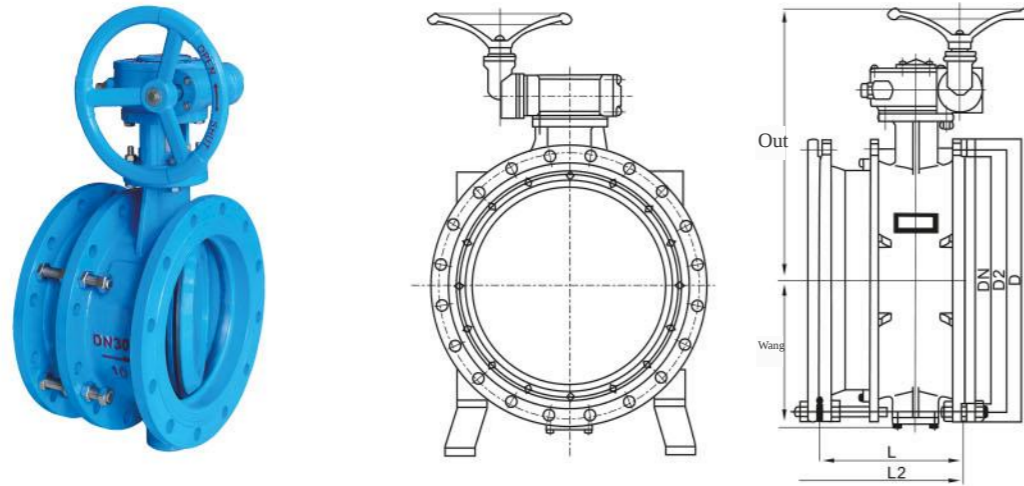

Main component materials

NO.	Component name	Material
1	Valve body	Ductile iron, carbon steel
2	Butterfly disc	Ductile iron, carbon steel, stainless steel
3	Valve shaft	Stainless steel
4	Sealing ring	Nitrile rubber
5	Filler	Flexible graphite

Technical parameters

Material used: Ductile iron, Carbon steel
 Size range: DN50mm~DN1400mm
 Pressure rating: 1.0MPa~1.6MPa
 Temperature range: -10°C ~ 80°C
 Applicable media: clean water, wastewater

Main External Connection Dimensions

Unit: mm

DN	L	L2	L1	D	D2	Z-d	H1	H2
50	158	168	178	165	125	4-19	80	155
60	164	174	184	185	145	4-19	80	155
80	168	178	188	200	160	8-19	97	173
100	181	193	205	220	180	8-19	110	220
125	196	203	210	250	210	8-19	125	255
150	198	213	228	285	240	8-23	143	258
200	213	228	243	340	295	8-23	170	310
250	230	242	253	395	350	12-23	220	355
300	241	258	275	445	400	12-23	225	380
350	256	278	300	505	460	16-23	253	422
400	287	312	337	565	515	16-28	284	486
450	295	325	345	615	565	20-28	308	497
500	310	330	350	670	620	20-28	335	560
600	343	364	385	780	725	20-31	390	715
700	394	414	434	895	840	24-31	483	782
800	405	428	450	1015	950	24-34	543	882
900	410	435	460	1115	1050	28-34	606	925
1000	530	560	590	1230	1160	28-37	655	1000
1200	570	602	630	1455	1380	32-40	778	1087
1400	630	665	700	1675	1590	36-43	912	1350
1600	720	760	800	1915	1820	40-49	1032	1475
1800	800	845	890	2115	2020	44-49	1154	1670
2000	910	1010	1110	2325	2230	48-49	1295	1780

Elastic Seat Eccentric Plug Valve

Product Overview

The resilient-seat eccentric plug valve is a new type of plug valve independently developed and produced by our company, incorporating our latest design concepts and manufacturing technology. Its resilient-seat structure overcomes the shortcomings of traditional plug valves, such as poor sealing performance and susceptibility to corrosion. The unique eccentric sealing design significantly reduces operating torque compared to traditional plug valves, minimizes wear on the sealing surfaces to the greatest extent, and extends the valve's service life. The rectangular straight-through flow passage ensures low head loss and excellent linear flow regulation. With its superior sealing, corrosion resistance, ideal operational performance, and long service life, it is suitable for urban sewage, industrial wastewater, slurry, clean water, and other working environments, serving as a shut-off or regulating device.

Technical Specifications

Nominal Diameter: DN50mm to DN800mm
 Nominal Pressure: 1.0MPa to 1.6MPa
 Operating Temperature: $0 - 70^{\circ}\text{C}$
 Strength Test Pressure: 1.5MPa to 2.4MPa
 Sealing Test Pressure: 1.1MPa to 1.8MPa
 Suitable working media: sewage, raw water, clean water, oils (NBR)
 Drive methods: handle type, transmission cap type, worm gear type, electric type, pneumatic type



PLVL handle type



PLVC rotating cap type



PLVP pneumatic type



PLVG Worm Gear Type



PLVE Electric Type

COLA/B/C (Hydraulic Control) Pipeline Force Valve

Product Overview

The COLA/B/C (Hydraulic Control) Pipeline Force Valve is developed by engineering technicians at Cambridge Valve Industry (Shanghai) Co., Ltd., referencing advanced domestic and international products of the same type. It is innovated based on the absorption of micro-resistance slow-closure check valves, hydraulic control check butterfly valves, and multi-functional hydraulic control valves, representing a new-generation upgrade for pump control valves. It integrates the functions of electric gate valves, electric butterfly valves, and check valves, while eliminating water hammer hazards through rapid-closing and slow-closing actions to protect the pump and pipeline network system safety.

This valve is the latest and most advanced in structure, with the most reliable performance, serving as a new type of control equipment for pumping stations. It is mainly used in centrifugal pumps for automated water supply and drainage pumping stations, as well as in water supply and drainage systems across industries such as metallurgy, petrochemicals, water conservancy, municipal works, and environmental protection.

Technical Parameters:

Material: Ductile iron, carbon steel

Size range: DN150mm~DN1600mm

Pressure rating: 1.0MPa~1.6MPa

Temperature range: -10°C~100°C

Applicable media: clean water, sewage, sludge discharge, seawater, oil products, etc.

Closing/opening time: adjustable (quick closing 1-3 seconds, slow closing 5-90 seconds)



Applicable occasions:

Applied in power, environmental protection, metallurgy, petrochemical, water conservancy, municipal, food and other industries for water supply and drainage systems, sewage pump houses, chemical fluid transport systems, etc.

1. Structure of the pipe force valve; This valve consists of components such as the valve body, rubber hose sleeve, large and small valve stem gates, upper and lower guide columns, etc.
2. Working principle of the pipe force valve: In conditions with high sediment and debris (such as Yellow River water quality, sewage treatment systems, etc.), the valve control pipeline is prone to clogging, leading to valve failure; large debris can also easily jam the valve plate, resulting in poor valve sealing; additionally, in some special circumstances, water hammer during valve opening or closing is significant, causing loud noise and even accidents.
3. The pipe force valve is the fifth-generation new product following traditional manual control valves, hydraulic butterfly valves, multi-function hydraulic valves, and hydraulic automatic valves at the pump outlet. Through fluid design of the valve, a linear flow passage is formed, featuring low energy consumption, stable operation, and effective sealing. It integrates the functions of electric gate valves, electric butterfly valves, and check valves. By reducing fast-closing time, it better eliminates water hammer hazards, protecting the safety of the pump and pipeline network system.
4. The force control valve is primarily used in the outlet pipelines of centrifugal pumps, mixed-flow pumps, and axial-flow pumps in automated water supply and drainage pumping stations. It is designed with two control mechanisms: piston type and diaphragm type, suitable for clear water, raw water media and sewage, slurry water media respectively. Through auxiliary components, it can provide real-time feedback on the valve's online operation status, enabling automatic control and remote monitoring functions for long-distance conveyance projects. In terms of product types, our company has developed five specifications including standard type, low-pressure backwater type, sewage type, etc., to meet the varying needs of different customers under different conditions. Due to its compact structure, small size, and light weight, it is particularly suitable for large-diameter pipeline systems.



Eccentric Semi-ball Valve

Applications and Features

The eccentric semi-ball valve features an offset between the center axis of the valve shaft and the center axis of the hemisphere, with the sealing pair only arranged on one side of the valve body. The structural form where the ball is installed into the valve body cavity from the upper end of the valve body (above the channel centerline) is generally referred to as the top-entry structure, abbreviated as top-entry type. The structural form where the ball of the semi-ball valve is installed into the valve body cavity from the side of the valve body is generally referred to as the side-entry structure, abbreviated as side-entry type.

Standards Adopted

Design Standard: GB/T26146-2010

Flange Connection Dimensions: GB/T17241.6-2008

Face-to-Face Dimensions:

GB/T26146-2010,

GB/T12221-2005

Pressure Test: GB/T26146-2010,

GB/T13927-2008

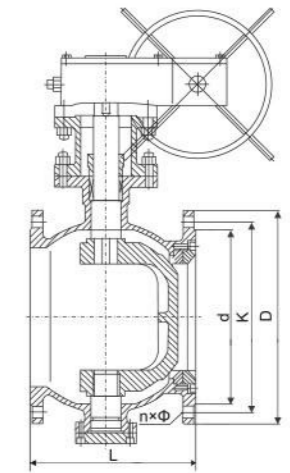

Main Performance and Parameters

Nominal Pressure		PN16	PN25	
Test Pressure	Shell Strength	2.4	3.75	MPa
	Liquid High-Pressure Seal	1.76	2.75	
	Gas Low Pressure Sealing	0.6	0.6	
Medium Temperature		-29 to 260°C		
Applicable Medium		Water, Steam, Oil, etc.		

Main Component Materials

Valve body, valve cover, packing gland	Cast steel, austenitic cast steel
Valve stem	Chromium stainless steel
Ball	Carbon steel, stainless steel
Valve seat	Polytetrafluoroethylene
Handwheel	Carbon steel, stainless steel
Drive method	Worm gear, electric

Main overall dimensions

Unit: mm

DN	L	D		K		d		C		f	n×Φ	
		PN16	PN25	PN16	PN25	PN16	PN25	PN16	PN25		PN16	PN25
50	178	165	165	125	125	99	99	20	20	2	4×18	4×18
65	190	185	185	145	145	118	118	20	22	2	4×18	8 by 18
80	203	200	200	160	160	132	132	20	24	2	8 by 18	8 by 18
100	229	220	235	180	190	156	156	22	24	2	8 by 18	8 by 22
125	254	250	270	210	220	184	184	22	26	2	8 by 28	8 by 26
150	267	285	300	240	250	211	211	24	28	2	8 by 22	8 by 26
200	292	340	360	295	310	266	274	24	30	2	12 by 22	12 by 26
250	330	405	425	355	370	319	330	26	32	2	12 by 26	12 by 30
300	356	460	485	410	430	370	389	28	34	2	12 by 26	16 by 30
350	450	520	555	470	490	429	448	30	38	2	16 by 26	16 by 33
400	530	580	620	525	550	480	503	32	40	2	16 by 30	16x36
450	580	640	670	585	600	548	548	40	46	2	20x30	20x36
500	660	715	730	650	660	609	609	44	48	2	20x33	20x36
600	800	840	845	770	770	720	720	54	58	2	20x36	20 by 39
700	900	910	960	840	875	794	820	40	50	5	24 by 36	24 by 42
800	1000	1025	1085	950	990	901	928	42	54	5	24 by 39	24 by 48
900	1100	1125	1185	1050	1090	1001	1028	44	58	5	28 by 39	28 by 48
1000	1200	1255	1320	1170	1210	1112	1140	46	62	5	28 by 42	28 by 55

Piston-type Electric Flow and Pressure Regulating Valve

Elastic Seat Eccentric Plug Valve

The HS941X Piston-type Electric Flow and Pressure Regulating Valve is developed based on fluid dynamics characteristics, drawing on advanced experience from Germany and Japan, and summarizing domestic design, manufacturing, and practical experience. It has been widely applied in fields such as power plants, water diversion, and water supply. The improved series of flow control valves are not only suitable for clean water but also exhibit good tolerance for natural river and lake water, as well as mildly polluted water. The design structure and material selection have resolved long-standing issues such as easy scaling, jamming, and oversized drive units in flow control valves.

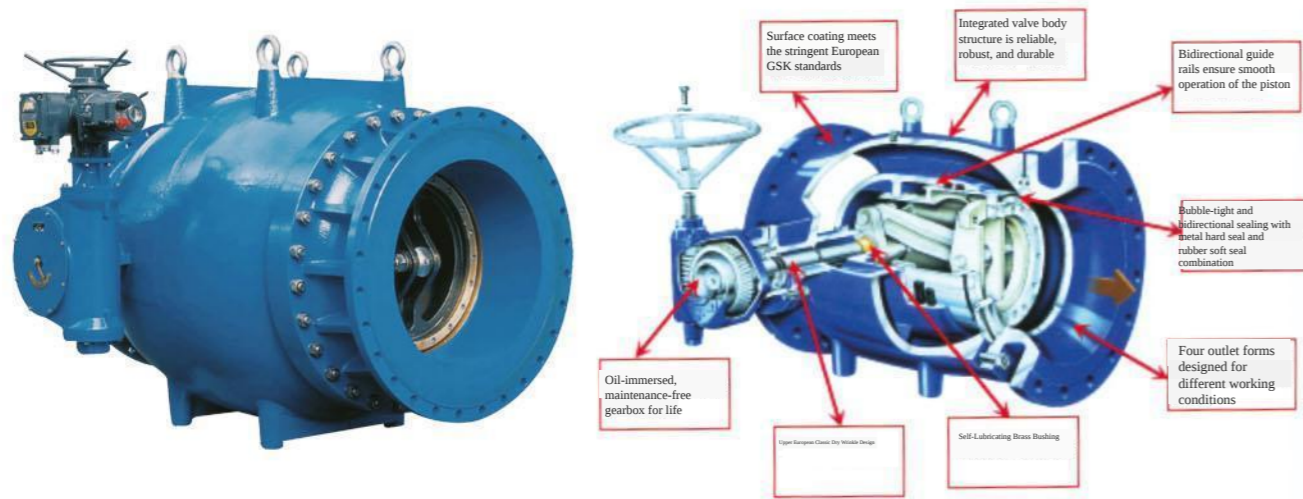

HS941X Piston-Type Electric Flow and Pressure Regulating Valve Product Operating Principle

The electric flow and pressure regulating valve is primarily used in pipeline network systems with water as the medium, such as in water plants, power plants, and water diversion projects, to regulate the flow, flow state, and pressure of the pipeline medium. The key advantage of this valve over traditional flow regulating valves lies in its structural design and material selection, which make it resistant to clogging by sewage, scaling, and jamming. The drive unit is significantly reduced in size. The valve can automatically adjust preset pipeline medium parameters to maintain them within a certain accuracy range, which can also be adjusted. It features excellent cavitation resistance, with the rib plates on the inner wall of the valve body also serving as flow straighteners to disperse water flow and prevent cavitation. This also reduces valve noise and piston vibration. The control system of the valve can utilize integrated electronic circuits, offering compact size, high reliability, good sensitivity, and easy installation and commissioning. With zero leakage when fully closed, it can function as a shut-off valve, eliminating the need for additional shut-off valves. If the control requirements and precision are not highly demanding, the valve can be operated manually or with a standard electric actuator. It can be installed horizontally or vertically.

Product Detailed Specifications

Nominal Pressure (MPa)	0.6-6.4 MPa
Leakage Rate	Complies with GB/T13927-1992 Standard
Applicable Temperature (°C)	0-80
Applicable Medium	Clean water, wastewater, raw water, etc.

Valve Name	Electric Multi-Function Piston Valve	
Nominal Pressure	1.0MPa, 1.6MPa	
Shell test pressure	1.5PN	
Seal test pressure	1.1PN	
Set pressure	1.0MPa	0.09-0.9MPa
	1.6 MPa	0.10-1.4 MPa
	2.5 MPa	0.15-2.2 MPa
Opening/closing differential pressure	≤10% of set pressure	

Material of Product Components

Serial Number	Name	Material
1	Front valve body	Ductile iron QT450-12 / Cast steel WCB
2	Crank	Stainless steel 304
3	Shear pin	Stainless steel 304
4	Connecting Rod	Stainless Steel 304
5	Flow Guide	Stainless Steel 304
6	Piston	Stainless Steel 304
7	Connecting Rod Support	Stainless Steel 304
8	Sealing Ring	Nitrile Rubber
9	Actuator	Intelligent Electric Actuator
10	Rear Valve Body	Ductile Iron QT450-12/ Cast Steel WCB
11	O-Ring	Nitrile Rubber
12	Drive shaft	Stainless steel 2Cr13
13	Front copper sleeve before sealing	ZCuSn10Zn2
14	Sealing copper sleeve	ZCuSn10Zn2
15	Fastener	Stainless Steel 25

Can be set according to working condition requirements

Flow Control Valve L

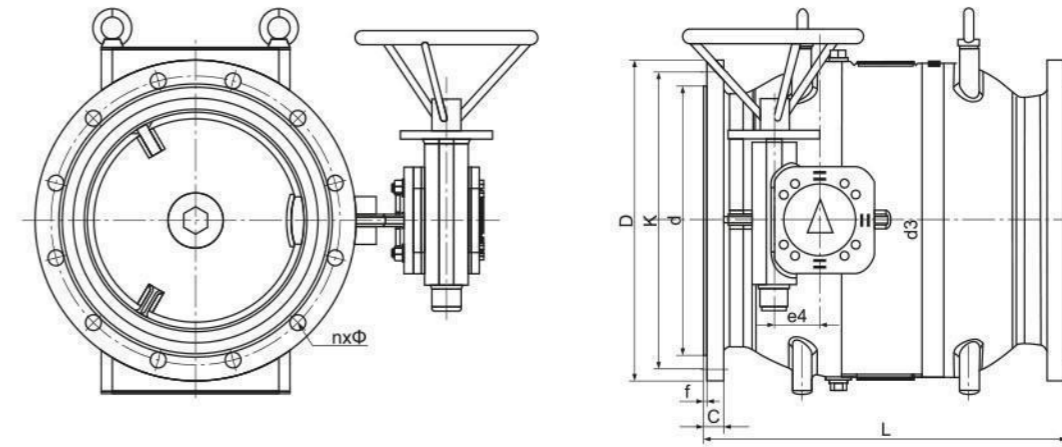

Main Performance and Parameters

Nominal Pressure	PN10	PN16	
Test Pressure	Shell Strength	1.5	2.4
	Liquid High-Pressure Sealing	1.1	1.76
Medium Temperature	-10 to 80°C		
Applicable Medium	Water, etc.		

Main Component Materials

Valve Body	Ductile Iron
Valve Cover	Ductile Iron
Valve Stem	Stainless Steel
Valve Key	Ductile Iron
Sealing Ring	Nitrile Rubber

Main External Dimensions

Unit: mm

DN	L	D		K		d		C		f	n times Φ	
		PN10	PN16	PN10	PN16	PN10	PN16	PN10	PN16		PN10	PN16
200	400	340	340	295	295	266	266	20	20	3	8 by 23	12 by 23
250	450	395	405	350	355	319	319	22	22	3	12 by 23	12 × 28
300	500	445	460	400	410	370	370	24.5	24.5	4	12 by 23	12 × 28
400	600	565	580	515	525	480	480	24.5	28	4	16 by 28	16×31
450	650	615	640	565	585	530	548	25.5	30	4	20×28	20×31
500	750	670	715	620	650	582	609	26.5	31.5	4	20 × 28	20×34
600	900	780	840	725	770	682	720	30	36	5	20 × 31	20×37
700	1050	895	910	840	840	794	794	32.5	39.5	5	24 × 31	24 × 37
800	1200	1015	1025	950	950	901	901	35	43	5	24 × 34	24 × 40
900	1350	1115	1125	1050	1050	1001	1001	37.5	46.5	5	28 × 34	28 × 40
1000	1500	1230	1255	1160	1170	1112	1112	40	50	5	28 × 37	28 × 43
1200	1800	1455	1485	1380	1390	1328	1328	45	57	5	32×40	32 × 49
1400	2800	1675	1685	1590	1590	1530	1530	46	60	4	36 by 43	36 × 49
1600	3200	1915	1930	1820	1820	1750	1750	49	65	5	40 by 49	40 × 56
1800	3600	2115	2130	2020	2020	1950	1950	52	70	5	44 by 49	44 × 56
2000	4000	2325	2345	2230	2230	2150	2150	55	75	5	48 by 49	48 × 62

Double Eccentric Hemisphere Valve

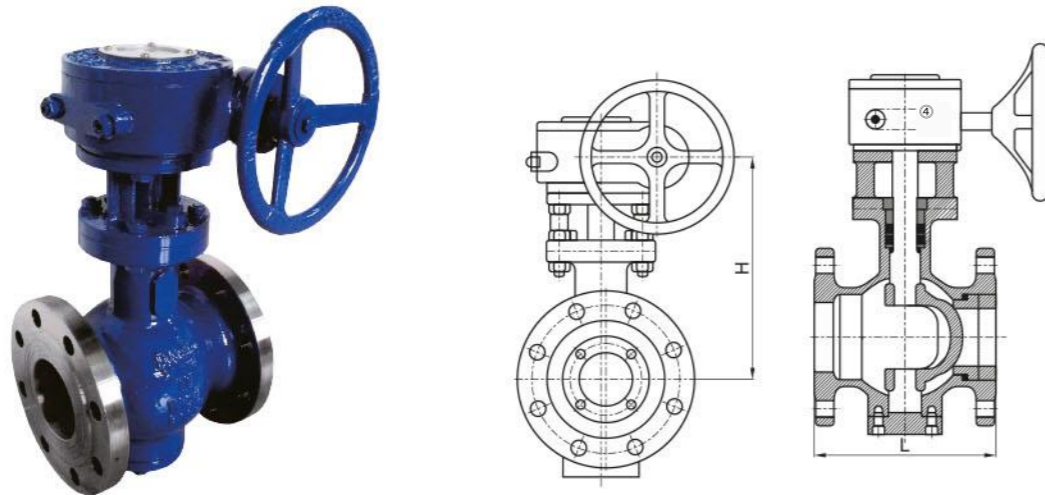

Product Detailed Specifications

Model	Valve Body	Ball	Bracket	Valve stem	Packing
H PQ40Y-10/16 F	QT450 WCB	QT450	QT450	WCB	PTFE Flexible Graphite
H PQ340Y-10/16 F		WCB	WCB	2Cr13	

Overview of Double Eccentric Hemisphere Valve

The double eccentric semi-ball valve utilizes an eccentric valve body, eccentric ball, and seat, with the valve stem automatically centering on a common trajectory during rotation, tightening progressively as it closes to achieve excellent sealing. The ball and seat completely separate, eliminating wear on the sealing ring and overcoming the constant wear issue between traditional ball seats and sealing surfaces. Non-metallic elastic material is embedded into the metal seat, providing good protection for the metal surface. This product is particularly suitable for media such as steel, aluminum, fibers, fine solid particles, pulp, coal ash, and petroleum gas.

Double Eccentric Semi-Ball Valve Product Features

- Its structure employs an eccentric tightening principle, achieving the purposes of sealing, adjustment, and closure through a transmission mechanism. The sealing pair is a metal-to-metal ring hard-face contact seal. The double eccentric structure positions the valve core within the ball chamber when open, providing a large flow area and protecting the valve from erosion; it also prevents erosion of the valve core when closed. During opening, the spherical surface of the valve core gradually moves along the valve seat, effectively cutting through scaling obstacles to achieve reliable sealing. It is particularly effective for mixed-flow transport where two-phase flow is prone to scaling and solid precipitation.
- The valve hemisphere uses bimetallic material, with different alloys overlaid on the base metal; the valve seat is also correspondingly overlaid and specially treated. The sealing surfaces are combined into various types such as corrosion-resistant, wear-resistant, and high-strength to meet the needs of different applications.
- Tight sealing, capable of achieving zero leakage when conveying hazardous gases.
- The valve core of the sealing pair has a compensation allowance; when the valve wears, turning it slightly further upon closing still ensures reliable sealing, extending the service life. Additionally, users can remove the tightening nut, and after adjustment or replacement, the valve seat remains usable, avoiding the drawback of discarding the entire valve after seal failure.

The selection of bimetallic sealing pairs with different alloys (or composite balls) through surfacing welding can be used in working conditions requiring wear resistance, corrosion resistance, high temperature resistance, and strict sealing.

- General-purpose valves: Specifications DN40-1600. Suitable for applications with stringent requirements such as sewage treatment, pulp, urban heating, and heat supply.
- Special valves for petroleum and chemical industries: Specifications DN40-1600. Suitable for various oil products like crude oil and heavy oil, as well as weakly corrosive and two-phase mixed media in the chemical industry.
- Special valves for gas: Specifications DN40-1600. Suitable for the transmission control of coal gas, natural gas, and liquefied gas.
- Slurry Special Valve: Specifications DN40-1600. Suitable for industrial pipeline transport involving liquid-solid two-phase mixed flow or liquid transport where chemical reactions cause crystallization or scaling.
- Coal Ash and Slag Special Valve: Specifications DN40-1600. Suitable for control in power plants, hydraulic slag removal, or gaseous transport pipelines.

Double Eccentric Hemisphere Valve Execution Standards

Design: GB12237-89

Flange connection: GB/T17241.6-1998, GB/T9115 (steel) Structure length: GB12221-89

Main component materials of double eccentric semi-ball valve

Name	Material
Valve body	QT450, WCB, ZG20CrMo, ZG1Cr18Ni9T
Valve shaft	2Cr13, 1Cr13
Valve disc	Alloy nitriding steel, nitriding stainless steel, wear-resistant steel
Valve seat	Alloy nitriding steel, nitriding stainless steel, wear-resistant steel
Bearings	Aluminum bronze, FZ-1 composite material
Fillers	Polytetrafluoroethylene, flexible graphite

Double Eccentric Hemisphere Valve Main Components Materials

Nominal Pressure (MPa)	0.6	1.0	1.6	2.5	4.0
Nominal Diameter (mm)	40-1600	40-1600	40-1200	40-600	40-600
Sealing test pressure (MPa)	0.66	1.1	1.76	2.75	4.4
Shell test pressure (MPa)	0.9	1.5	2.4	3.75	6.0
Applicable temperature (°C)	-29~300, -29~425, -29~540				
Applicable medium	Fresh water, seawater, sewage, liquids such as acids and alkalis, slurry, steam, gas, oils				
Drive Method	Manual, Electric, Pneumatic				
Connection Type	Flange Connection, Wafer Connection				
Installation Method	Vertical Installation, Horizontal Installation				

100X remote control float valve / 106X electric remote control floating ball valve

Product Features

Maintains water level in the pool/tank within the set range

When the water level drops to the lower limit, the main valve opens to start supplying water to the pool/tank

When the water level rises to the upper limit, the main valve closes to stop supplying water to the pool/tank

Simple and reliable design, easy to install and maintain

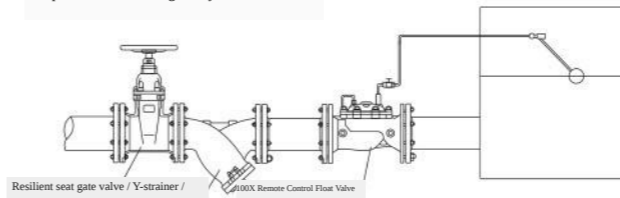

Product Features

Maintains water level in the pool/tank within the set range

When the water level drops to the lower limit, the main valve opens to start supplying water to the pool/tank

When the water level rises to the upper limit, the main valve closes to stop supplying water to the pool/tank

Simple and reliable design, easy to install and maintain

When the float ball fails, the solenoid valve can control the water level from being too high



200X Adjustable Pressure Reducing Valve

Product Features

Sensitive, precise, and stable pressure control

Adjustable downstream pressure

Downstream pressure remains constant regardless of flow changes or upstream pressure variations

Simple and reliable design, easy to install and maintain

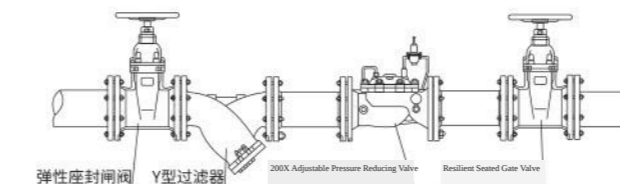

300X Slow-Closing Check Valve

Product Features

Operates using the pipeline's own pressure

Simple and reliable design

When water hammer occurs at the downstream outlet, the main valve closes quickly to prevent water hammer from rapid opening. When the downstream pressure is higher than the upstream pressure, the high downstream pressure is directed into the upper chamber of the main valve, closing it. This automatically eliminates destructive water hammer, protecting the pump and pipeline from damage.

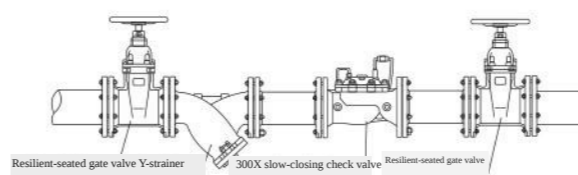

Application

Used at the pump outlet in industrial water supply and drainage, wastewater treatment plants, and high-rise buildings to prevent backflow of the medium in the pipeline network.

400X Flow Control Valve

The 400X Flow Control Valve is a multifunctional valve that uses a high-precision pilot-operated method to control flow. It is suitable for pipelines in water distribution systems where flow and pressure need regulation, maintaining a preset flow rate unchanged, limiting excessive flow to a predetermined value, and appropriately reducing upstream high pressure. Even if the pressure upstream of the main valve changes, it does not affect the flow downstream. This valve deviates from the conventional principle of throttle valves that use orifice plates or purely mechanical means to reduce flow area; instead, it utilizes related pilot valves to minimize energy loss during throttling. In emergencies, the 400X Flow Control Valve can completely shut off flow to prevent losses. It features high control sensitivity, safety, reliability, easy adjustment, and a long service life.

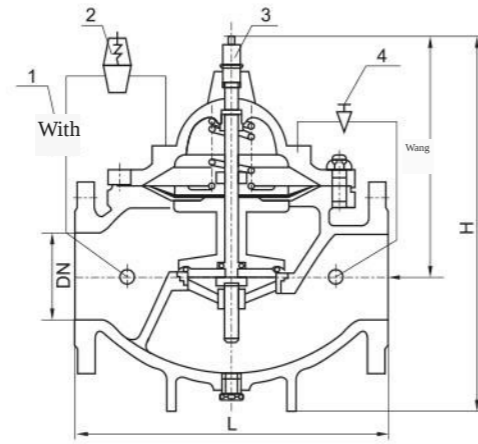

1. Ball valve 2. Pilot valve 3. Flow regulator 4. Needle valve

500X Pressure Sustaining Valve

Product Features

Quick opening and closing—maintains pipeline pressure

Slow closing—prevents water hammer

When the upstream pressure exceeds the set value, the main valve opens to relieve excess pressure from the upstream pipeline.

When the upstream pressure falls below the set value, the main valve closes to maintain upstream pressure.

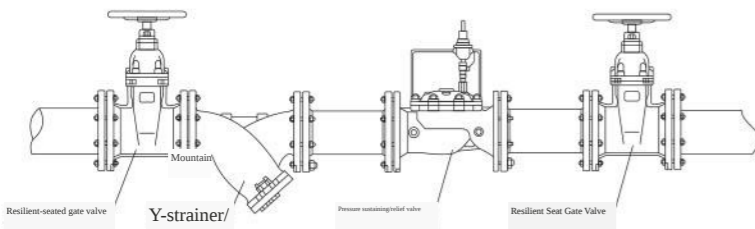

Function

Pressure Sustaining: Maintains the minimum pressure setting upstream with a full pipeline

Pressure Relief: Releases excess pressure from the upstream pipeline, reducing or preventing secondary water hammer

Application

Installed in series in the pipeline to maintain the pressure setpoint: ensures the minimum pressure required for elevated users, prevents pipeline emptying and delays reservoir refilling, maintains the minimum pump head, and prevents cavitation by limiting flow
 Bypass pressure relief installation; drains when pressure reaches set value; prevents pipeline overpressure when a component is shut off; prevents pump operation at excessively low flow according to pump curve

600X Electric Control Valve

Product Features

Simple and reliable product design

High-quality solenoid valve control

Normally open type: control center commands solenoid valve to close, main valve shuts off to stop water supply

Normally closed type: the control center controls the solenoid valve to open, the main valve opens to start water supply

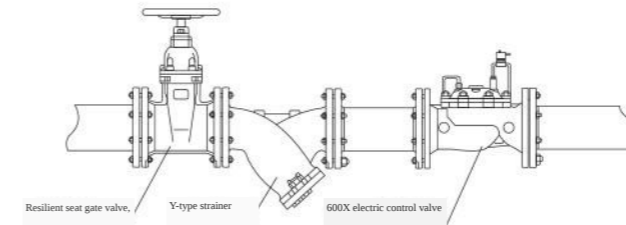

Function

Remotely control pipeline shutdown, or continue water supply, regardless of inlet and outlet pressure fluctuations; manually control shutdown, or continue water supply

Application

When the pump is turned on, keep the valve closed/open

Electronic sensor controls opening or closing

Can also be used for liquid level control by using a level sensor to transmit open or close signals

Automatically resets to open or closed state when power is cut off

700X Pump Control Valve

The 700X pump control valve is a type of check valve installed at the outlet of pumps in high-rise buildings and other water supply systems to prevent backflow of the medium. Before the pump stops supplying water, the valve slowly closes about 90% first to prevent water hammer and impact noise caused by sudden pump shutdown; after the pump completely stops, the valve fully closes to prevent pumped water from flowing back, effectively protecting the pump from reverse rotation due to backflow impact. This product is an essential protective device at the pump outlet. The valve features a streamlined design and achieves precise opening and closing through solenoid valve pilot control, ensuring safe and reliable operation, effectively preventing water hammer and impact noise, with a long service life and convenient installation and maintenance.

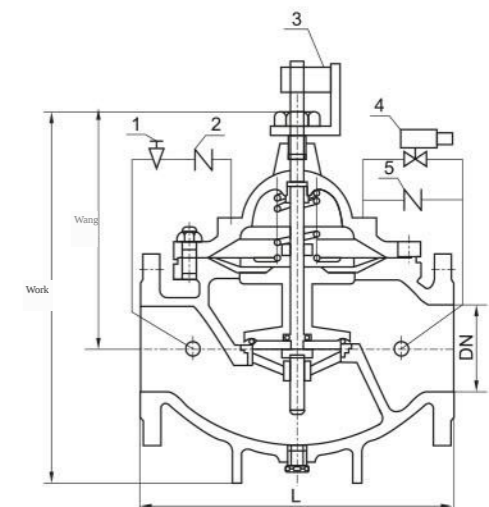

1. Needle valve 2. Check valve 3. Limit switch 4. Solenoid valve 5. Check valve

800X Differential Pressure Bypass Balancing Valve / 900X Emergency Shut-off Valve

The 800X Differential Pressure Balancing Valve is a valve used between the supply and return water in air conditioning systems to balance differential pressure. This valve improves system efficiency, maintains a precisely constant differential pressure, minimizes system noise, and prevents damage to equipment caused by excessive pressure differences. The advantage of the 800X Differential Pressure Balancing Valve over other balancing valves is that it has no actuator, relying entirely on the medium's own pressure differential to achieve system balancing, saving energy and installation space, making it an intelligent valve.

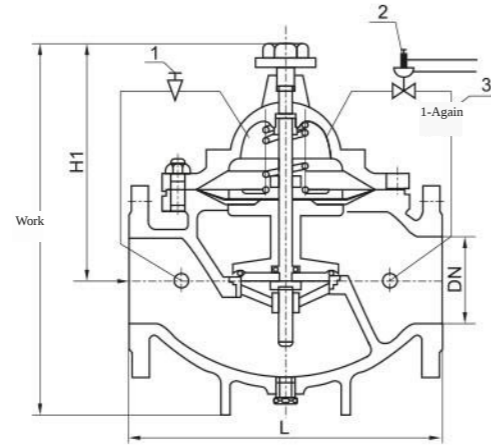

1. Needle Valve 2. Pilot Valve 3. Ball Valve

900X Emergency Shut-off Valve

The 900X emergency shut-off valve is a valve used in parallel water supply systems for both firefighting and domestic water, designed to regulate the direction of water supply. In the event of a fire, when a large amount of water is urgently needed for firefighting, the 900X emergency shut-off valve immediately cuts off the domestic water supply to ensure sufficient firefighting water. When firefighting stops and water pressure decreases, the valve automatically opens, returning to its normally open state and restoring the domestic water supply. This valve eliminates the need for a separate dedicated firefighting water supply pipeline, significantly saving construction costs and water consumption. The valve features high control sensitivity, safety, reliability, easy adjustment, and a long service life.

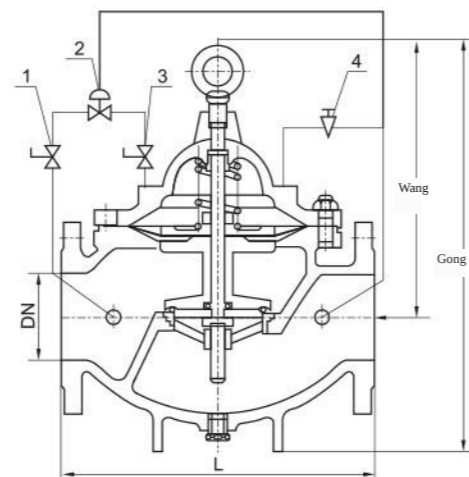

1. Small ball valve 2. Pilot valve 3. Flow regulator 4. Needle valve

CAMBRIDGE VALVE Series Backflow Preventer

Cambridge Valve Group's newly applied design product, the most innovatively designed backflow preventer, one of the drafting units for the new national standard GB/T25178 (pressure-reducing backflow preventer).

Product Features

- Professional product design, fully utilizing 3D printing technology
- Highly sensitive, high-strength nylon fiber reinforced diaphragm
- 1 million on-off cycle tests
- Destructive testing at 5 times working pressure
- Most parts are precision machined by CNC
- High-temperature epoxy powder coating ensures corrosion resistance and service life
- Different product materials and packaging materials meet various market and certification requirements
- High-standard product pressure testing
- Low-pressure sealing test: 0.05 MPa
- High-pressure sealing test: $1.1 \times PN + 0.1$ MPa
- Shell strength test: $1.5 \times PN + 0.1$ MPa
- Relief pressure differential: 0.02MPa
- Easy installation, simple adjustment, and maintenance-free



Product features

- Low water loss
- Compact structure
- Pressure fluctuation without leakage (patented technology)
- High safety
- Online maintenance



Working Principle

The Cambridge backflow preventer series is a hydraulically controlled combination device independently developed by our company, designed for urban water supply and similar units to strictly ensure that pressurized water in pipelines flows only in one direction when supplying to general pollution-prone units. Its function is to effectively prevent media of poorer quality at the outlet end from flowing back into the higher-quality inlet end during siphon backflow or backpressure backflow in the water supply system, thereby avoiding contamination of domestic drinking water, ensuring the safety of domestic water supply, and achieving the goal of preventing backflow pollution.



CAMBRIDGE VALVE Series Backflow Preventer

Product Structural Features

More compact structure, shorter dimensions, smaller size, lower water loss, and reduced noise; operates normally with a working water loss of 1.3-2.5 meters at economic flow rates.

The accuracy and adjustable drainage pressure of the drain valve minimize interference from pipeline pressure fluctuations, ensuring safe and reliable opening and closing with no abnormal drainage.

Single diaphragm design, with proven reliability of key components like the diaphragm, gives it superior quality over ordinary low-resistance backflow preventers.

The unique flow channel design of the two-stage check valve offers low flow resistance and fast opening/closing, effectively preventing damage from sudden backpressure surges, restricting pressure water backflow or siphon backflow, featuring silent operation and extending valve service life.

Ergonomic design; the product can be installed horizontally or vertically, with online testing and online maintenance.

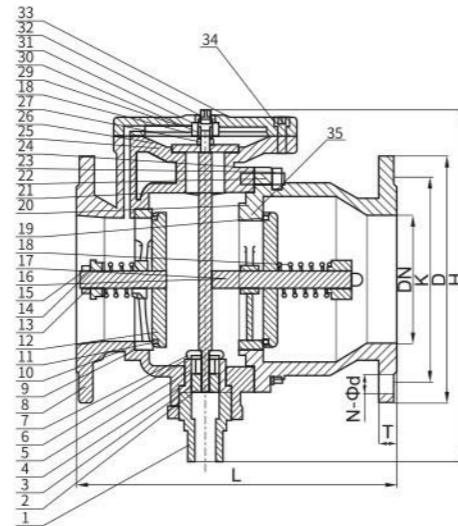

Serial Number	1	2	3	4	5	6	7
Part Name	Drain Connector	Drain Spring	Drain valve seat	O-ring	Guide vane nut	Spacer sleeve	Drain valve disc
Material	304	304	304	EPDM	304	PTFE	304
Serial Number	8	9	10	11	12	13	14
Part Name	Main Valve Body	Front Valve Seat	Front Valve Disc	Spring Seat	Spring	O-ring	Valve stem
Material	QT450-10	304	304+EPDM	304	304	EPDM	304
Serial number	15	16	17	18	19	20	21
Part name	Rear seat	Rear disc	O-ring	Sub-valve body	O-ring	Double-ended stud	Hex Nut
Material	304	304+EPDM	EPDM	QT450-10	EPDM	304	304
Serial Number	22	23	24	25	26	27	28
Part Name	Diaphragm Pressure Plate	Diaphragm	Diaphragm upper pressure plate	Hex nut	Valve cover	Hex socket screw	Hex bolt
Material	304	EPDM	304	304	QT450-10	304	304

CAMBRIDGE VALVE Series Backflow Preventer

Product Design Standards

Valve inspection and pressure testing comply with GB/T13927

Valve face-to-face dimensions comply with GB/T12221.

Flange dimensions comply with GB/T17241.6.

Valve surfaces are coated with epoxy resin powder before assembly and

Complies with GB/T17219 regulations



Main structural dimensions

Model	DN	L	H	D		K		n-Φd	
				PN10	PN16	PN10	PN16	PN10	PN16
JQDSSP741X -10/16	50	230	250	165	165	125	125	4-Φ19	4-Φ19
JQDSSP741X -10/16	65	236	286	185	185	145	145	4-Φ19	4-Φ19
JQDSSP741X -10/16	80	276	300	200	200	160	160	8-Φ19	8-Φ19
JODSSP741X -10/16	100	298	347	220	220	180	180	8-Φ19	8-Φ19
JODSSP741X -10/16	125	303	365	250	250	210	210	8-Φ19	8-Φ13
JQDSSP741X -10/16	150	364	404	285	285	240	240	8-Φ23	8-Φ23
JQDSSP741X -10/16	200	470	520	340	340	295	295	8-Φ23	12-Φ23
JODSSP741X -10/16	250	470	520	395	405	350	355	12-Φ23	12-Φ28
JODSSP741X -10/16	300	580	680	445	460	400	410	12-Φ23	12-Φ28
JODSSP741X -10/16	400	740	900	565	580	515	525	16-Φ28	16-Φ32
JODSSP741X -10/16	500	900	1100	670	715	620	650	20-Φ28	20-Φ32
JQDSSP741X-10/16	600	1030	1300	780	840	725	770	20-FZO	20-Φ41

Product Structural Features

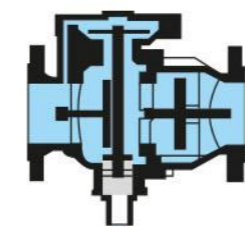

Normal Operating State

Inlet pressure higher than outlet pressure, both check valves open, normal operation, drain valve closed

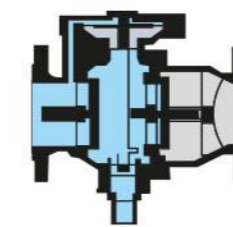

Downstream Pressure Excessively High

When the outlet pressure is higher than the inlet pressure, both the front and rear check valves close, the drain valve opens, the medium in the intermediate chamber is emptied, forming an air gap.

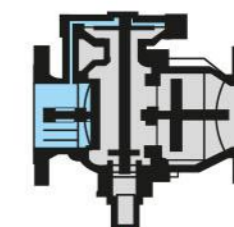

Downstream Check Valve Failure

When the outlet pressure is higher than the inlet and the outlet check valve fails, the inlet check valve closes, the drain valve opens, and water from the downstream flows out through the drain outlet without backflowing upstream.

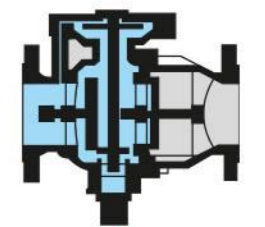

Upstream Check Valve Failure

When the inlet check valve fails, the outlet check valve remains closed, and the medium flows out from the drain outlet, neither entering downstream nor backflowing upstream.

CAMBRIDGE VALVE Series Backflow Preventer

Low Resistance Backflow Preventer (Design and Manufacturing Standard: JB/T11151-2011)

Product Overview

The low-resistance backflow preventer is a hydraulically controlled combination device independently developed by our company, primarily used in urban water supply and similar systems to strictly ensure that pressurized water in pipelines flows only in one direction. Its function is to effectively prevent media of poorer quality at the outlet end from flowing back into the higher-quality inlet end when siphonic backflow or backpressure backflow occurs in the water supply system. This avoids contamination of potable water, ensures its safety, and achieves the goal of preventing backflow pollution.



Scope of Application

Primarily used for effective isolation between municipal water supply networks and user networks, or between different water quality systems such as domestic water, firefighting water, air conditioning water, and irrigation water; its main function is to prevent media with poorer water quality at the outlet end from leaking into the inlet end with better water quality when the valve is closed and various potential internal leaks exist, thereby avoiding backflow contamination. It should be equipped with internal leak detection and drainage diversion devices. It can also be used for branch pipe sources with harmful contamination and continuous pressure flow, but not for preventing backflow in toxic contamination scenarios.

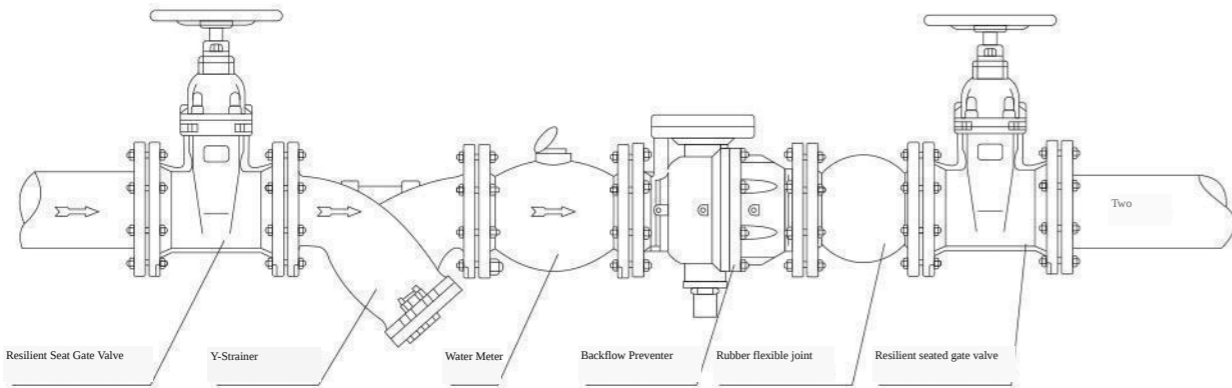

Reduced pressure type backflow preventer (Design and manufacturing standard: GB/T25178-2010)

Product Overview

The reduced pressure type backflow preventer is a hydraulically controlled combination device independently developed by our company, primarily used in urban water supply and other water supply units to strictly ensure that pressurized water in pipelines flows only in one direction. Its function is to effectively prevent media of poorer quality at the outlet end from backflowing to the higher-quality inlet end when siphonic backflow or backpressure backflow occurs in the water supply system, thereby avoiding contamination of domestic water and ensuring its safety, achieving the goal of preventing backflow pollution. It also provides a certain pressure-reducing function, effectively protecting the safety of the outlet pipeline network.



Maintenance and Service

The backflow preventer has a long maintenance cycle, operates reliably with automated control, and does not require frequent or meticulous maintenance. Inspection and repair are needed only when faults such as periodic leakage or continuous leakage under non-leaking conditions are detected. No special tools are required for maintenance, but it should be performed by approved technical personnel, taking care to avoid mixing up components of the inlet check valve, outlet check valve, and drain valve.

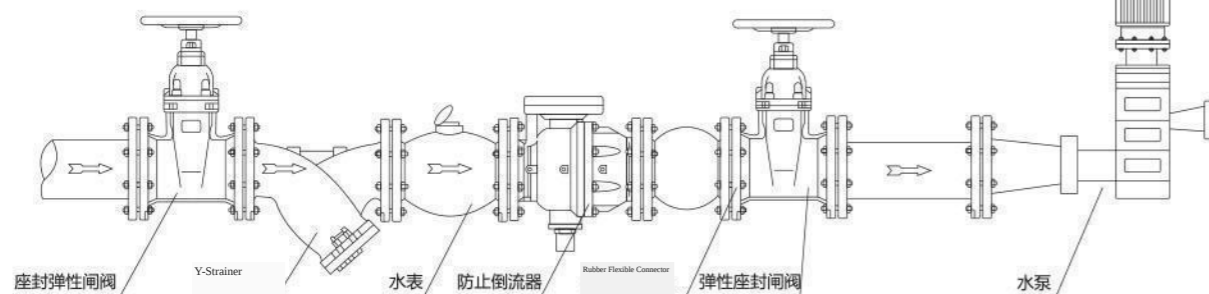

CAMBRIDGE VALVE Series Backflow Preventer

Double Check Backflow Preventer (Design and Manufacturing Standard: CJ/T160-2010)

Product Overview

The double check backflow preventer is a hydraulically controlled combination device independently developed by our company, designed for urban water supply units and general pollution units to strictly ensure that pressurized water in pipelines flows only in one direction. Its function is to prevent the backflow of medium in the pipeline under any working conditions, thereby achieving the goal of avoiding backflow contamination. It is suitable for locations without drainage conditions.



Product Features

1. More compact structure, shorter dimensions, smaller size, low backflow, low noise, with a normal working water loss of 1.3-2.5 meters at economic flow rates.
2. The unique flow channel design of the two-stage check valve features low flow resistance and fast opening/closing speed, effectively preventing damage to the valve and pipeline from sudden backpressure surges, restricting backflow or siphon backflow of pressure water, and offering a silent operation function, effectively extending the valve's service life.
3. User-friendly design, the product can be installed horizontally or vertically, with online testing and online maintenance capabilities.

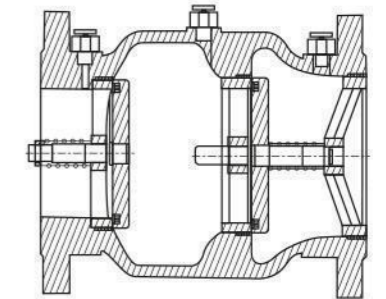

JQSDFQ4X Double Check Backflow Preventer Structural Dimensions

Nominal Diameter	D1		D2		D3		N-D1		L	T
	1.0MPa	1.6 MPa	1.0 MPa	1.6 MPa	1.0 MPa	1.6 MPa	1.0 MPa	1.6 MPa		
DN50	165		125		99		4-Φ19		185	19
DN65	185		145		118		4-Φ19		210	19
DN80	200		160		132		8-Φ19		225	19
DN100	220		180		156		8-Φ19		250	19
DN150	285		240		211		8-Φ23		340	19
DN200	340		295		266		8-Φ23	12-Φ23	400	20

JQDSBP711X-16 Waterproof Backflow Preventer for Meter Idle Running

Product Overview

At this stage, backflow preventers are generally not installed for residential water supply connections; very few households have even installed ordinary check valves to prevent medium backflow. The structurally complex backflow preventers, if installed in users' homes, cannot achieve drainage, and with their high cost and significant investment, they do not align with China's national conditions. Ordinary check valves are prone to damage, making it difficult to prevent backflow of the medium into the household and to stop water meters from spinning idle, posing major risks to civilian water supply. Our company's independently developed anti-idle-spinning backflow preventer is a hydraulic control device that restricts water in the pipeline to one-way flow. It prevents medium backflow in the pipeline, stops water meters from spinning idle, ensures water safety, and prevents water pollution.



Design Standard

Design and manufacturing requirements shall comply with CJ/T160-2010 regulations

Performance testing requirements as specified in CJ/T160P2010

Threaded connection requirements as specified in GB/T7306.2-2000

Product Features

Straight-through design, large flow area, water resistance close to zero

Compact structure, short overall length, easy installation

Simple structure, safe and reliable

Effectively prevents water meter idling and stops medium backflow

Installation Method

Pipes must be flushed before formal installation

Can be installed horizontally or vertically

During installation, ensure the medium flow direction matches the valve arrow

Diaphragm-type Multi-function Water Pump Control Valve

Product Overview

The JD745X Diaphragm-type Multi-function Water Pump Control Valve is an intelligent valve installed at the outlet of water pumps in high-rise building water supply systems and other water supply systems, designed to prevent media backflow, water hammer, and water shock. This valve integrates the three functions of an electric valve, check valve, and water hammer eliminator, effectively enhancing the safety and reliability of the water supply system. It combines the technical principles of slow opening, quick closing, and slow closing to eliminate water hammer, preventing both pump-start and pump-stop water hammer. Simply operate the pump motor start/stop button, and the valve will automatically open or close according to pump operation procedures, offering high flow capacity and minimal pressure loss. The diaphragm type is suitable for valves with diameters under 600.

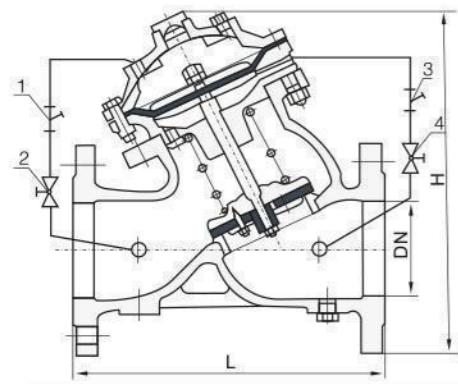

1. Filter 2. Small ball valve 3. Filter 4. Small ball valve



Diaphragm-Type Remote Float Valve

Product Overview

The F745X diaphragm-type remote control float valve is a hydraulically operated valve that integrates multiple functions. It is primarily installed at the inlet of water tanks or elevated water towers. When the water level reaches the preset height, the main valve, controlled by the float pilot valve, closes the inlet to stop water supply; when the water level drops, the main valve opens the inlet under the control of the float pilot valve to refill the tank, achieving automatic water replenishment. The liquid level control is precise and free from interference; the diaphragm-type remote control float valve can be installed at any position according to the height and available space of the tank, offering convenient maintenance, adjustment, and inspection, reliable sealing, and a long service life. The diaphragm-type valve features reliable performance, high strength, and balanced operation, suitable for pipelines with diameters up to 450.

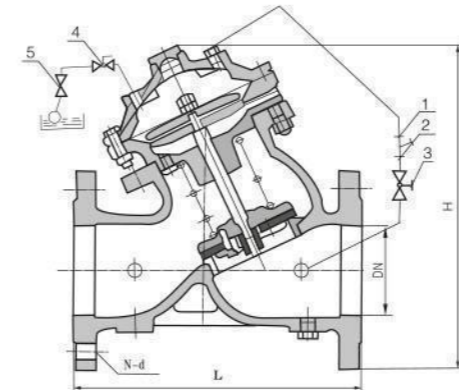

1. Filter 2. Needle valve 3. Small ball valve 4. Small ball valve 5. Small float valve



Typical installation diagram

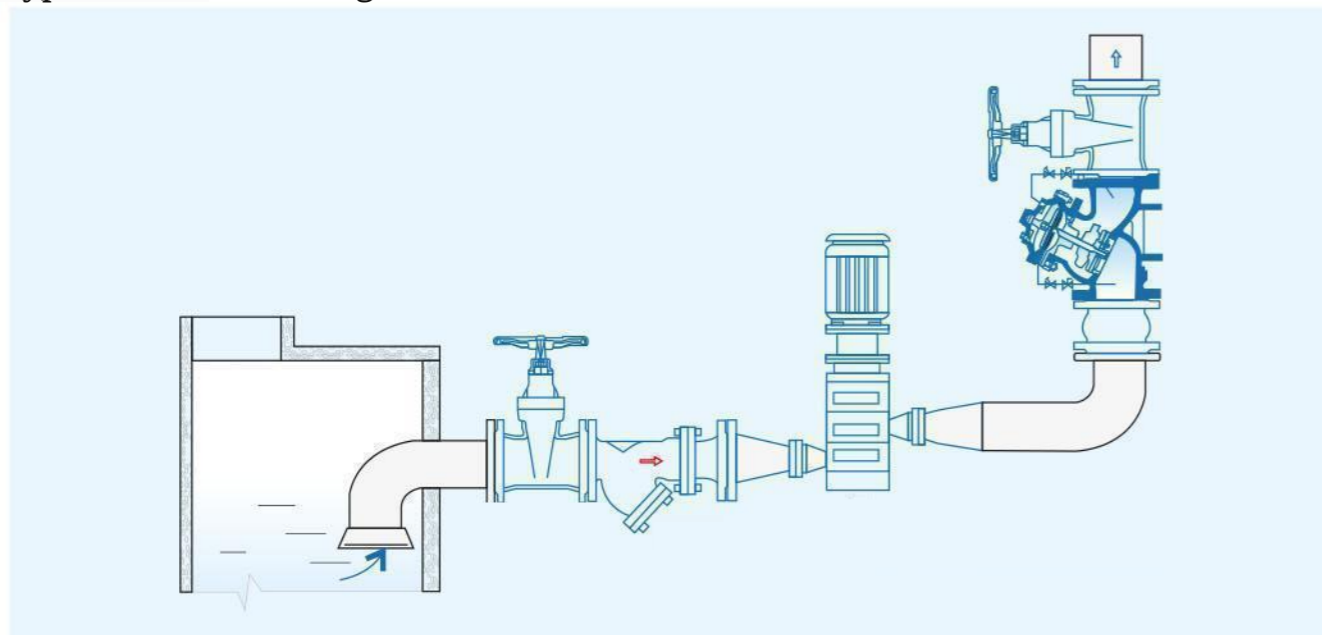

Typical installation diagram

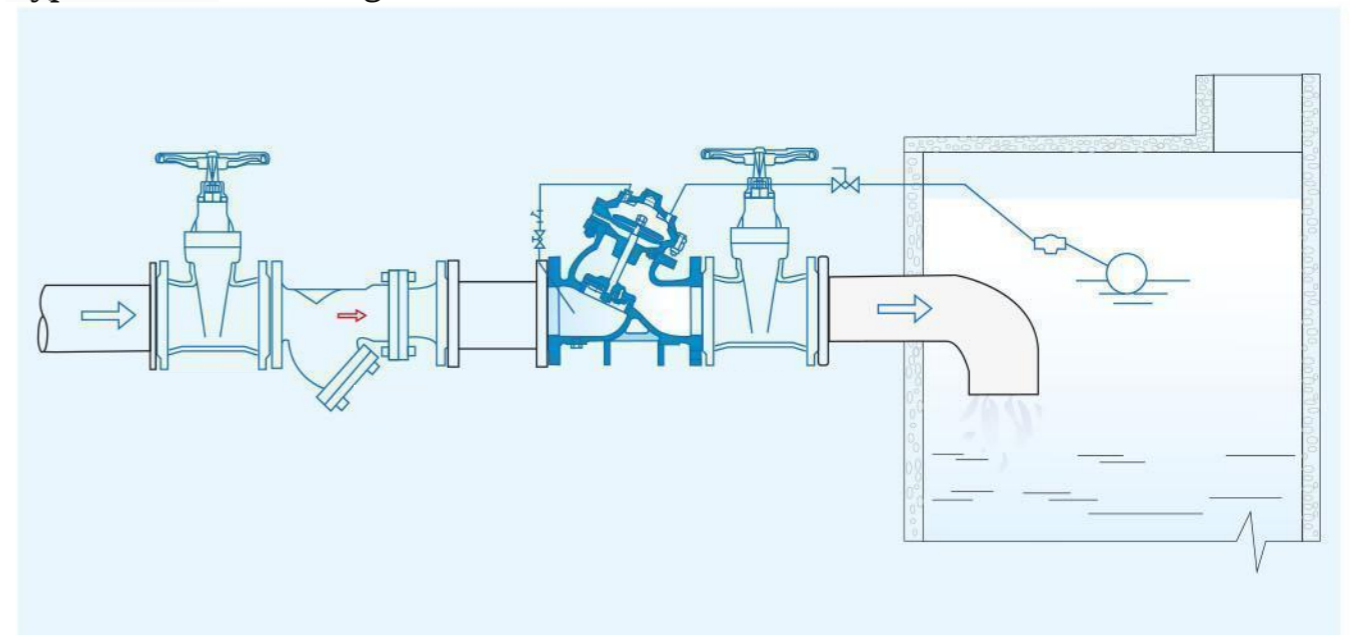

Main External Connection Dimensions

Unit: mm

DN	50	65	80	100	125	150	200	250	300	350	400	450	500	600	700	800	900	1000	1200
L	203	216	241	292	330	356	457	533	610	686	762	864	914	1067	1300	1450	1650	1800	2000
H	293	328	364	418	481	543	673	729	927	957	1188	1218	1256	1600	1800	1870	1980	2300	2600

Main external connection dimensions

Unit: mm

DN	50	65	80	100	125	150	200	250	300	350	400	450	500	600
L	203	216	241	292	330	356	457	533	610	686	762	864	914	1067
H	293	328	364	418	481	543	673	729	927	957	1188	1218	1256	1600

Diaphragm Type Adjustable Pressure Reducing and Stabilizing Valve

Product Overview

The YX741X Diaphragm Type Adjustable Pressure Reducing and Stabilizing Valve is installed in the water supply and drainage system pipelines of high-rise buildings to reduce the inlet pressure to a required outlet pressure. This special valve uses its own energy to keep the outlet pressure stable at the set value, meaning the outlet pressure does not change with variations in inlet pressure or flow rate. The valve's control system is equipped with a self-cleaning filter at the inlet, utilizing fluid characteristics to prevent larger, heavier suspended particles from entering the control system, ensuring unimpeded circulation and safe, reliable operation. The system is responsive and has a long service life.

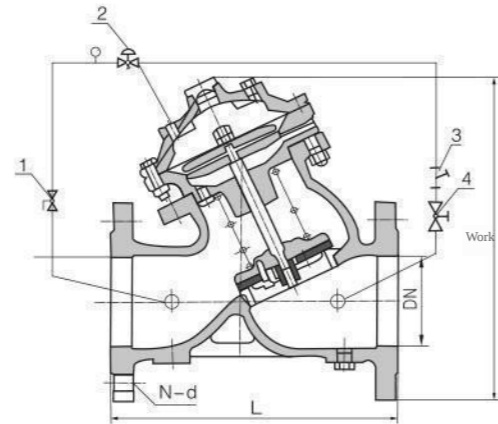

1. Small ball valve 2. Pilot valve 3. Filter 4. Small ball valve

Typical installation diagram

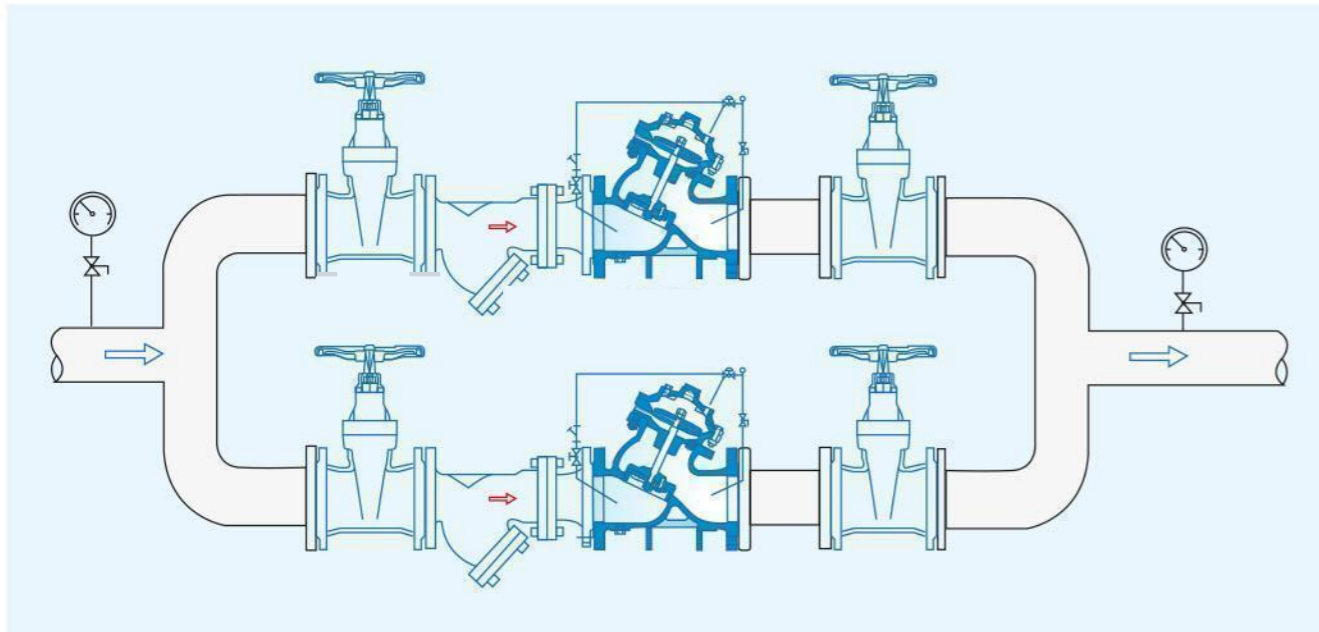

Main External Connection Dimensions

Unit: mm

DN	50	65	80	100	125	150	200	250	300	350	400	450	500	600
L	203	216	241	292	330	356	457	533	610	686	762	864	914	1067
H	300	337	467	520	580	640	778	889	1010	1037	1264	1294	1324	1600

Diaphragm Type Safety Relief/Pressure Sustaining Valve

Product Overview

The AX742X Diaphragm Type Safety Pressure Relief/Sustaining Valve is installed on pipelines in high-rise buildings, fire-fighting water supply systems, and other water supply systems. When the pressure in the water supply pipeline exceeds the set pressure of the relief valve, the valve automatically opens to quickly relieve pressure, protecting the pipeline's safety. It can also function as a sustaining valve to maintain the water supply pressure upstream of the main valve. It ensures an accurately constant safety set pressure; once overpressure occurs, the relief valve opens promptly to relieve pressure in time. It closes with reliable balance, eliminating residual pressure fluctuations.

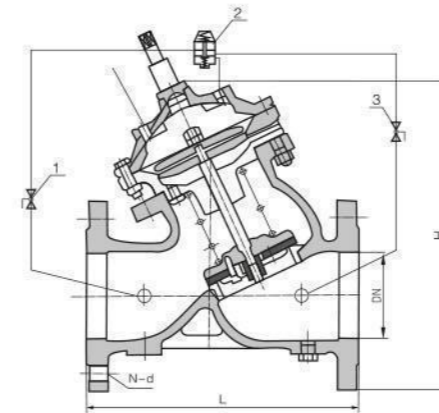

1. Small Ball Valve 2. Pilot Valve 3. Small Ball Valve



Typical Installation Diagram

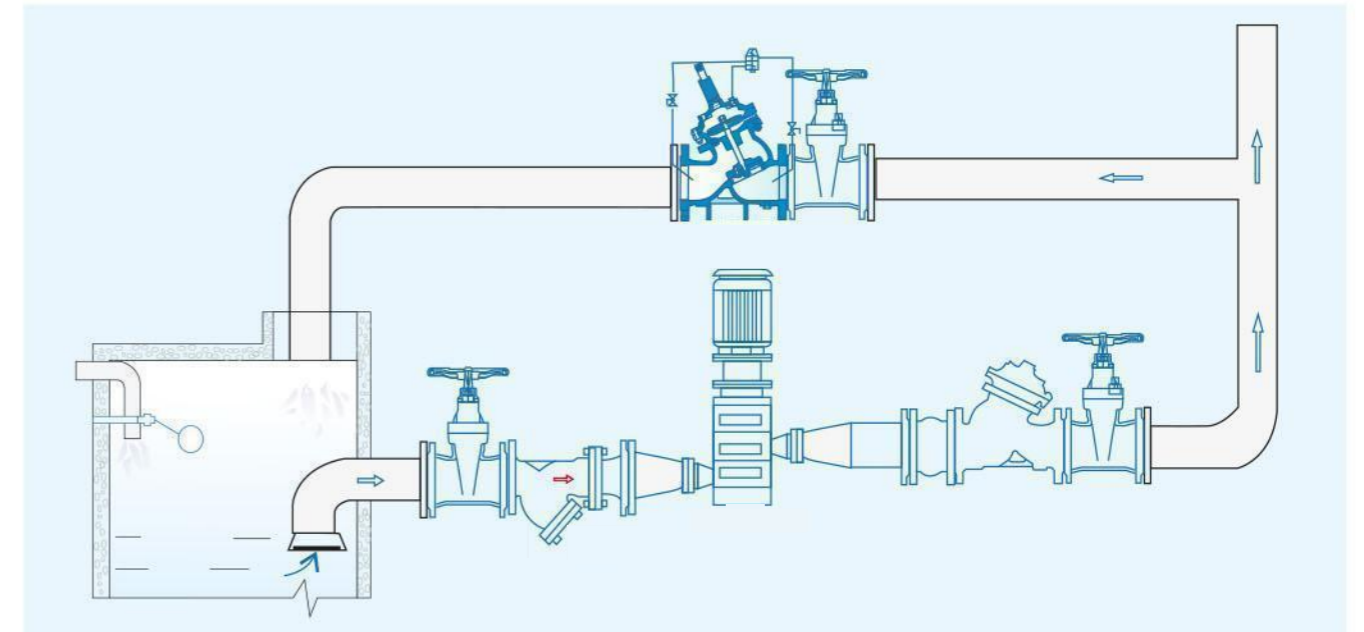

Main External Connection Dimensions

Unit: mm

DN	50	65	80	100	125	150	200	250	300	350	400	450	500	600
L	203	216	241	292	330	356	457	533	610	686	762	864	914	1067
H	300	337	467	520	580	640	778	889	1010	1037	1264	1294	1324	1600

Diaphragm-type electric remote control valve

Product Overview

Installed on pipelines of various water supply systems, the valve opens or closes based on electrical signals or manual operation, with accurate and rapid control response. Adjustable closing speed allows the valve to close smoothly without causing pressure fluctuations. Utilizes a three-way solenoid valve for simple maintenance.

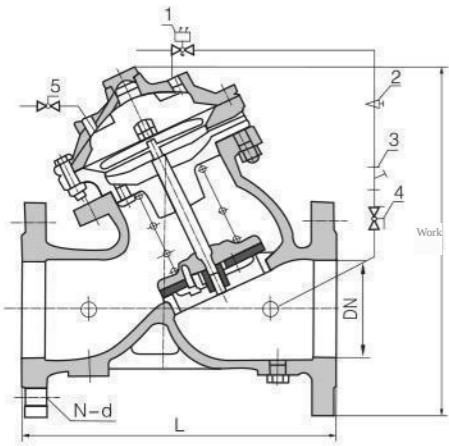

1. Solenoid pilot valve 2. Needle valve 3. Filter 4. Small ball valve 5. Small ball valve



Typical Installation Diagram

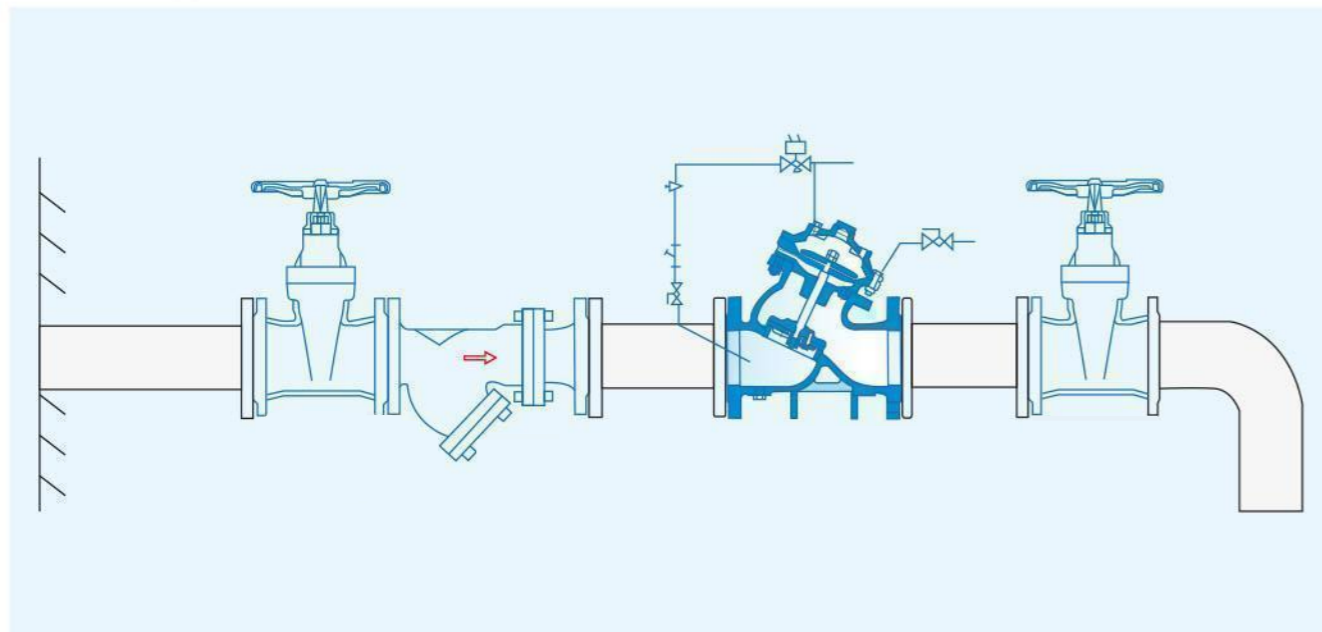

Main External Connection Dimensions

Unit: mm

DN	50	65	80	100	125	150	200	250	300	350	400	450	500	600
L	203	216	241	292	330	356	457	533	610	686	762	864	914	1067
H	320	367	400	452	522	592	696	810	943	1200	1230	1230	1270	1600

Piston-type multi-function water pump control valve

Product Overview

The DS101/201X piston-type multifunctional pump control valve is installed at the outlet of pumps in large-diameter water supply pipeline systems, serving as an intelligent valve that prevents media backflow, water hammer, and water surge. This valve integrates three functions: an electric valve, a check valve, and a water hammer eliminator, effectively enhancing the safety and reliability of water supply systems. Its dual-chamber, dual-disc structure allows the valve to close 90% rapidly after pump shutdown (preventing reverse rotation of the pump due to backflow media) and then slowly close the remaining 10% (eliminating destructive water hammer). The piston-type valve offers reliable performance, high strength, and balanced operation, suitable for preventing both pump-start and pump-stop water hammer scenarios. Simply operate the pump motor start button, and the valve automatically opens or closes according to pump operation procedures, featuring high flow capacity and minimal pressure loss.

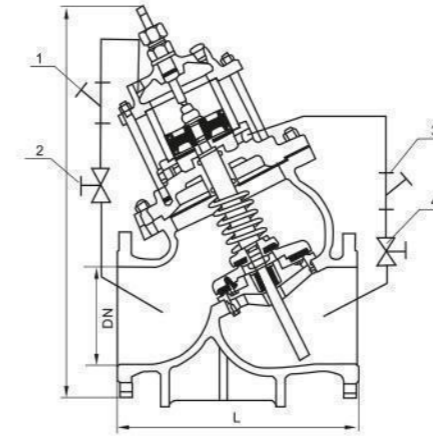

1. Filter 2. Ball valve 3. Filter 4. Ball valve



Typical installation diagram

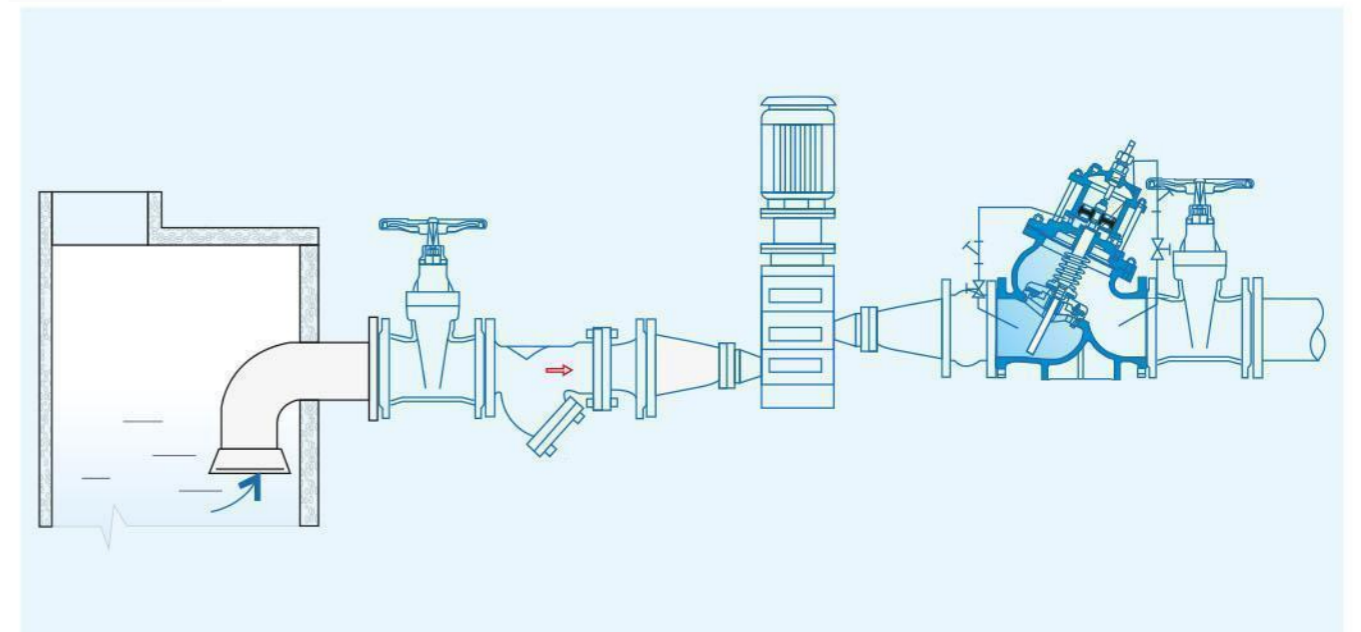

Main external connection dimensions

Unit: mm

DN	50	65	80	100	125	150	200	250	300	350	400	450	500	600	700	800	900	1000	1200	1400
L	203	216	241	292	330	356	457	533	610	686	762	864	914	1067	1300	1450	1650	1800	2000	2350
H	293	328	364	418	481	543	673	729	927	957	1188	1218	1600	1800	2000	2300	2600	2700	2860	3200

Low Resistance Backflow Preventer

Product Overview

The LHS745X online-maintenance low-resistance backflow preventer integrates multiple functions. In addition to ultra-low resistance and more reliable safety performance, its valve body is designed with expansion joint and filter screen devices, shortening the overall installation length and reducing the installation volume, bringing great convenience and benefits to customers. The LHS745X low-resistance backflow preventer is an online-maintenance type, featuring a filter screen and expansion flange at the inlet. It operates on the principle of hydraulic control valves, employing a control method entirely different from pressure-reducing backflow preventers. This ensures the safety of air-gap-level isolation while effectively reducing head loss; at a flow velocity $V=2.5\text{m/s}$, the head loss $h=2\sim 3\text{m}$, essentially meeting the requirements of an ideal backflow preventer. It is mainly used for effective isolation between urban water supply networks and various user networks, or between cross-connections of systems such as potable water and non-potable water, fire water, air conditioning water, and irrigation water, or for installation with non-negative pressure equipment, strictly preventing backflow contamination.

Product Features

1. Ultra-low water loss, significant energy saving: At economic flow rate (2 m/s flow velocity), head loss is less than 3 meters;
2. Air gap, automatic drainage: When the main valve closes, the drain automatically opens, depressurizing the intermediate cavity to zero, achieving an air gap or zero-pressure gap between upstream and downstream of the valve, ensuring safe and reliable isolation performance.
3. Space and material saving, flexible installation: Compact size, lightweight, equipped with built-in strainer and expansion joint, structural length is only 30% of existing similar products.
4. Easy maintenance, automatic alarm capability: Inspection requires no specialized pressure detector; can be configured with automatic water leakage alarm.



Detailed Parameters

Model	Nominal Diameter (mm)	Nominal Pressure	Opening Pressure	Local Head Loss	Isolation Type	Valve Body Material	Internal Parts Material	Applicable Temperature
LHS745X-10QLHS745X-16Q	DN65~DN400	1.0MPa-1.6MPa	$\leq 0.03\text{MPa}$	$\leq 0.03\text{MPa}$	Air gap or zero-pressure gap	Ductile iron/stainless steel	304 stainless steel	$\leq 80^\circ\text{C}$

Debugging steps

Before formally installing the backflow preventer, flush all pipelines thoroughly to eliminate other unrelated issues. After installation, during initial startup, to prevent damage from sudden movements such as O-ring displacement and internal component harm, it is necessary to follow these steps: close the outlet gate valve, slowly open the inlet gate valve to allow water to gradually fill the valve cavity, open each test ball valve to vent air from the valve cavity. Once the valve cavity is filled with water, slowly open the outlet gate valve to allow water to fill the entire pipeline.

Working Principle

Forward water flow: When the inlet pressure is greater than the outlet pressure, the two check valve discs open, and the drainer closes. At a flow velocity of 2m/s, the flow water loss is less than 0.04MPa.

Reverse closure: When the inlet pressure is less than or equal to the outlet pressure, the two check valve discs close, and the drainer opens.

If there is no debris blockage, the two check valve discs seal and close, the drainer outlet does not drain, the intermediate cavity communicates with the atmosphere, and the pressure in the intermediate cavity is zero.

Prevention of backflow contamination: When the inlet pressure is less than the outlet pressure, the two check valve discs are in the closed state, and the drainer is in the open state if one or both of the check valve discs

Debris jams the valve port, causing leakage; the leaked medium flows into the intermediate chamber and is discharged directly outside the valve through the drainer, preventing backflow contamination to the inlet side.

Product Type

1. Built-in Drain Type Low-Resistance Backflow Preventer
DN ≤ 50 Threaded Connection, divided into: LHS711X Type DN15-DN25 LHS712X Type DN32-DN50
Note: The LHS711X type product does not have a test ball valve or inlet filter screen.
2. Straight-Through Type Low-Resistance Backflow Preventer
Flange connection Model: LHS743X type DN50-DN200
3. Online maintenance type low resistance backflow preventer
Flange connection Model: LHS745X type DN150-DN400

Hydraulic control slow-closing check butterfly valve

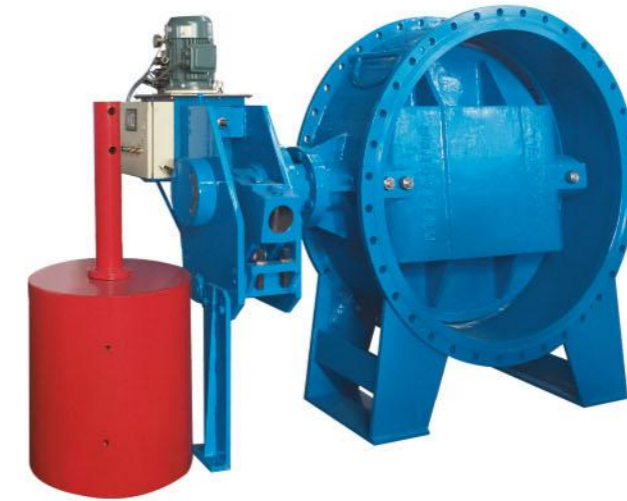

DN		PN MPa	L	L0	L1	L2	L3	L4	L5	L6	L7	H1	H2	H3	D	Medium	n-d	n-d1	Mass kg
mm	in																		
400	16	1.0	216	1107	527	650	341	420	90	900	995	370	417	900	565	515	16-Φ28	6-Φ26	1155
		1.6	216	1107	527	650	341	420	90	900	995	370	417	900	580	525	16-Φ31	6-Φ26	1175
450	18	1.0	222	1143	552	680	352	420	90	900	995	400	417	900	615	565	20-Φ28	6-F2	1200
		1.6	222	1143	552	680	352	420	90	900	995	400	417	900	640	585	20-F31	6-F2b	1280
500	20	1.0	229	1212	582	710	391	500	100	1100	995	430	417	1100	670	620	20-F28	6-F2b	1310
		1.6	229	1212	582	710	391	500	100	1100	995	430	417	1100	715	650	20-F34	6-N26	1410
600	24	1.0	267	1335	651	780	439	540	110	1100	995	480	417	1100	780	725	20-FZ1	6-430	1800
		1.6	267	1335	651	780	439	540	110	1100	995	480	417	1100	840	770	20-FZ7	6-F30	1920
700	28	1.0	292	1484	728	850	517	680	120	1100	995	530	417	1100	895	840	24-F31	6-430	2240
		1.6	292	1484	728	850	517	680	120	1100	995	530	417	1100	910	840	24-F37	6-Φ30	2360
900	32	0.6	318	1681	799	940	585	760	145	1445	1080	600	455	1445	975	920	24-Φ34	6-Φ33	2540
		1.0	318	1681	799	940	585	760	145	1445	1080	600	455	1445	1015	950	24-Φ34	6-Φ33	2565
		1.6	318	1681	799	940	585	760	145	1445	1080	600	455	1445	1025	950	24-Φ40	6-Φ33	2700
800	36	1.0	330	1811	864	1000	650	800	150	1445	1080	660	455	1445	1115	1050	28-Φ34	6-Φ33	2780
		1.6	330	1811	864	1000	650	800	150	1445	1080	660	455	1445	1125	1050	28-Φ40	6-Φ33	2940
1000	40	0.6	410	1956	929	1060	730	900	180	1445	1080	690	455	1445	1175	1120	28-Φ31	6-Φ36	3560
		1.0	410	1956	929	1060	730	900	180	1445	1080	720	455	1445	1230	1160	28-Φ37	6-436	3570
		1.6	410	1956	929	1060	730	900	180	1445	1080	720	455	1445	1255	1170	28-Φ43	6-Φ36	3770

GB/T 12241.6-1998, GB/T 9113.1-2000

2. The weight in the table is for reference only; subject to the actual product.

Hydraulic Control Slow-closing Check Butterfly Valve

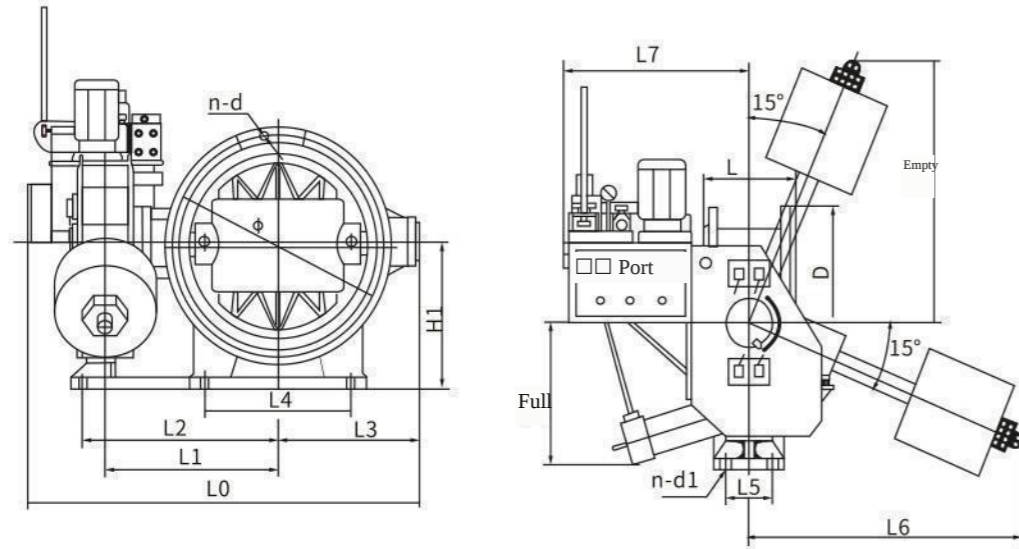

DN		PN MPa	L	L0	L1	L2	L3	L4	L5	L6	L7	H1	H2	H3	D	Φ	n-d	n-d1	Quality Kg
mm	in																		
1200	48	0.6	470	2254	1083	1250	860	1050	200	2010	1150	830	550	2010	1405	1340	32-Φ34	6-Φ39	4050
		1.0	470	2254	1083	1250	860	1050	200	2010	1150	850	550	2010	1455	1380	32-Φ40	6-Φ39	4265
1400	56	0.6	530	2554	1230	1390	998	1160	240	2010	1150	930	550	2010	1630	1560	36-Φ37	6-Φ42	4850
		1.0	530	2554	1230	1390	998	1160	240	2010	1150	950	550	2010	1675	1590	36-Φ43	6-Φ42	5130
1600	64	0.6	600	2924	1419	1600	1145	1450	300	2290	1360	1035	550	2290	1830	1760	40-Φ37	6-Φ48	6520
		1.0	600	2924	1419	1600	1145	1490	300	2290	1360	1080	550	2290	1915	1820	40-Φ49	6-Φ48	6760
1800	72	0.6	670	3147	1527	1710	1260	1600	350	2290	1360	1150	650	2290	2045	1970	44-Φ40	6-Φ48	9580
		1.0	670	3147	1527	1710	1260	1600	350	2290	1360	1180	650	2290	2115	2020	44-Φ49	6-Φ48	9760
2000	80	0.6	760	3454	1672	1880	1397	1780	380	2540	1580	1250	650	2540	2265	2180	48-Φ43	6-Φ48	10940
		1.0	760	3454	1672	1880	1397	1780	380	2540	1580	1280	650	2540	2325	2230	48-Φ49	6-Φ48	11215
2200	88	0.6	770	3681	1784	1990	1512	1860	400	2540	1580	1360	650	2540	2475	2390	52-Φ43	6-Φ48	12280
		1.0	770	3681	1784	1990	1512	1860	400	2540	1580	1400	650	2540	2550	2440	52-Φ57	6-Φ48	12600
2400	96	0.25	780	3955	1905	2110	1615	2040	420	2540	1580	1470	1000	2540	2605	2540	56-Φ34	6-Φ48	15100
		0.6	780	3955	1905	2110	1615	2040	420	2540	1580	1470	1000	2540	2685	2600	56-Φ43	6-Φ48	15360
2600	104	0.25	790	4340	2125	2330	1780	2100	450	2540	1580	1580	1000	2540	2805	2740	60-Φ34	6-Φ48	17490
		0.6	790	4340	2125	2330	1780	2100	450	2540	1580	1580	1000	2540	2905	2810	60-Φ49	6-Φ48	17780

GB/T17241.6-1998, GB/T9113.1-2000

2. The weights in the table are for reference only; actual products shall prevail.

Micro-resistance slow-closing check valve

Product Overview

The HH44X micro-resistance slow-closing check valve is used in water supply and drainage pipelines, installed at the pump outlet to prevent media backflow and eliminate destructive water hammer. It effectively reduces the water hammer pressure during valve closure, ensuring the safe operation of the pipeline network. It features a lightweight disc, large opening, significant energy-saving effect, low fluid resistance, a novel water hammer elimination mechanism, stable and reliable sealing performance, wear resistance, long service life, smooth operation, no vibration, and no noise.

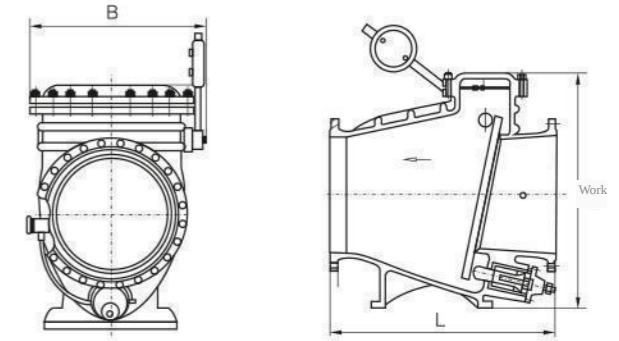

Typical Installation Diagram

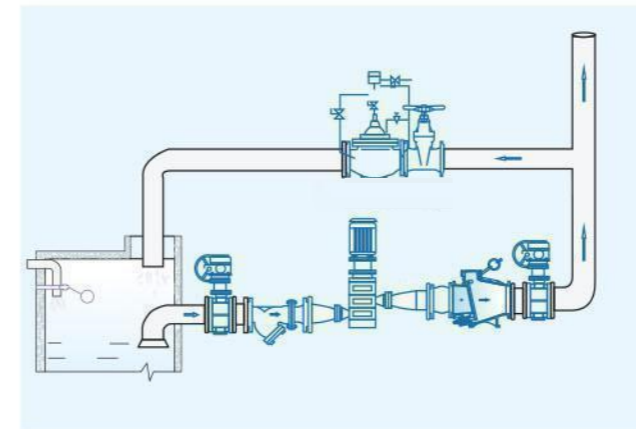

Technical Parameters

Nominal Pressure: 1.0~2.5 MPa
 Nominal Diameter: 40~800 mm
 Applicable media: water, weakly corrosive liquids
 Applicable temperature: 0~80°C (up to 200°C if required)
 Flange standard: GB/T17241.6GB/T9113
 Test standard: GB/T13927API1598

Main component materials

Part name	Valve body, valve cover	Valve disc	Valve shaft
Material	Gray cast iron, cast steel	Steel plate, rubber assembly	Stainless Steel

Main Outline Connection Dimensions

Unit: mm

DN	40	50	65	80	100	125	150	200	250	300	350	400	450	500	600	700	800
L	200	230	290	310	350	400	480	500	600	700	800	900	1000	1100	1300	1400	1500
H	300	300	320	354	350	380	500	580	670	730	820	920	950	1100	1200	1550	1700
B	220	270	290	300	320	340	410	450	550	580	630	700	800	900	990	1120	1300

Slight-Resistance Slow-Closing Butterfly Check Valve

Product Overview

The HH46/48/49H slight-resistance slow-closing butterfly check valve is used in drainage pipelines for media such as clean water, sewage, and seawater. It not only prevents backflow of the medium but also effectively limits destructive water hammer, ensuring pipeline safety. It features a novel structure, compact size, light weight, low fluid resistance, reliable sealing, smooth operation, wear resistance, long service life, oil pressure and slow-closing unaffected by the medium, and good energy-saving effects.

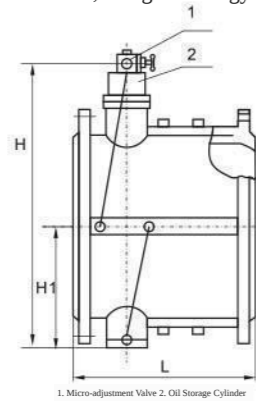

Typical Installation Diagram

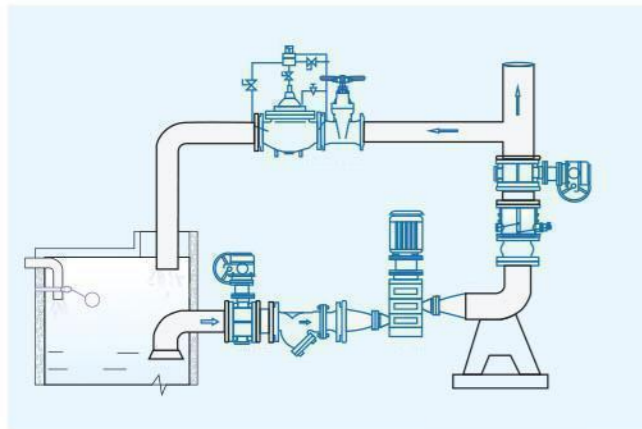

Technical parameters

Nominal pressure: 1.0~2.5 MPa
 Nominal diameter: 40~1000 mm
 Slow-closing time: 3~60 seconds
 Applicable media: clean water, wastewater, seawater
 Applicable temperature: 0~80°C (up to 200°C if required)
 Flange standard: GB/T17241.6 GB/T9113
 Test standard: GB/T13927 API1598

Material of main components

Part name	Valve body	Valve disc	Valve stem, cylinder, piston	Spring	Valve seat
Material	Cast iron, cast steel	Carbon steel	Stainless steel	Stainless steel	Nitrile rubber

Main external connection dimensions

Unit: mm

DN	40	50	65	80	100	125	150	200	250	300	350	400	450	500	600	700	800	900	1000
L	140	150	170	180	190	200	210	230	250	270	290	310	330	350	390	430	470	510	550
H	200	215	225	235	280	290	310	350	415	450	480	550	585	640	720	780	840	990	1050
B	88	98	108	118	130	148	172	210	240	264	297	324	351	379	434	491	549	600	655

Butterfly Buffer Check Valve

Product Overview

The HH47/H47XF/HDH47X Butterfly Buffer Check Valve is primarily used at the pump outlet in industrial water supply and sewage treatment plants to prevent backflow of media in the pipeline network. It automatically eliminates destructive water hammer, thereby protecting the pump and pipeline from damage. The valve mainly consists of a valve body, disc, buffer device, and fine adjustment valve. This product features a novel structure, compact size, low fluid resistance, stable operation, reliable sealing, wear resistance, and excellent buffering performance, making it the optimal choice for industrial water and sewage applications.



Typical Installation Diagram

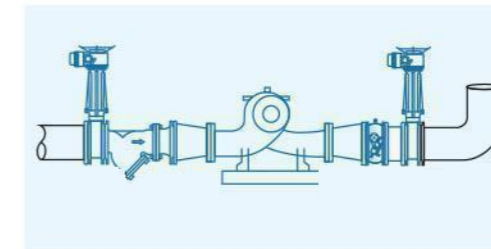

Technical Parameters

Nominal Pressure: 1.0~2.5MPa
 Nominal Diameter: 40~1400mm
 Applicable Media: Water, Oil, Seawater, Sewage Applicable
 Temperature: 0~80°C (up to 200°C if required)
 Flange Standard: GB/T17241.6 GB/T9113
 Test Standard: GB/T13927 API1598

Main Component Materials

Part Name	Valve Body	Butterfly Plate	Sealing Ring	Spring	Packing
Material	Gray cast iron, carbon steel	Gray cast iron, cast steel, ductile iron	Nitrile oil-resistant rubber, neoprene	Stainless steel	Polytetrafluoroethylene

Micro-resistance slow-closing silent check valve

Product Overview

The DHH44 type micro-resistance slow-closing check valve is primarily used at the outlets of industrial and municipal water supply and drainage pipelines, high-rise residential buildings, luxury hotels, and pressurized water pump systems. Its design fully considers environmental requirements, employing an inclined disc structure to achieve vibration-free, noiseless, and smooth operation, ensuring quiet environments in hotels and residences while offering energy-saving benefits. By utilizing a delayed closing mechanism, it allows partial backflow to dissipate within the system, significantly reducing the water pressure impact from pump-stop backflow and eliminating destructive water hammer peaks. The shut-off seal uses nitrile rubber, featuring excellent sealing performance, shock absorption, wear resistance, long service life, and easy maintenance.



Typical installation diagram

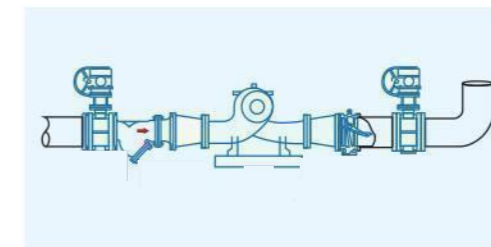

Technical parameters

Nominal pressure: 1.0~1.6 MPa
 Nominal diameter: 200~2000 mm
 Applicable media: clean water, slurry water, seawater, sewage
 适用温度: 0~80°C
 Flange standard: GB/T17241.6GB/T9113
 Test standard: GB/T13927API1598

Main Component Materials

Part Name	Valve Body	Butterfly Plate	Sealing Ring	Valve Stem	Buffer oil
Material	Gray cast iron, carbon steel	Carbon steel	Nitrile rubber	Stainless steel	Stainless steel

Silent Check Valve DRVZ

Product Overview

The DRVZ silent check valve mainly consists of valve body, valve seat, guide body, valve disc, bearing, spring, and other key components, featuring a streamlined internal flow path design with minimal pressure loss. The valve disc has a very short opening and closing stroke, allowing rapid closure when the valve or pump stops to prevent loud water hammer noise, characterized by silent closure.

This valve is primarily used in water supply and drainage, fire protection, and HVAC systems, and can be installed at the pump outlet to prevent backflow and water hammer damage to the pump.



Main component materials

Valve body, flow guide	Valve seat, bearing, valve disc, shaft	Spring
Ductile iron, gray cast iron	Aluminum bronze or chromium stainless steel	Stainless Steel

Typical Installation Diagram

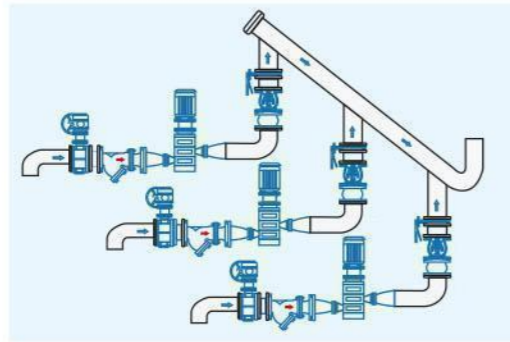

Technical Parameters

Nominal pressure: 1.0~2.5 MPa
 Nominal diameter: 50~350 mm
 Applicable media: water, oil products, seawater, sewage
 Applicable temperature: 0~80°C
 Flange standard: GB/T17241.6GB/T9113
 Test standard: GB/T13927API1598

Double Disc Check Valve DDRX

Product Overview

The DDRX double disc check valve mainly consists of key components such as the valve body, valve disc, valve stem, and spring.

This valve is primarily suitable for water supply systems, high-rise buildings, and industrial areas. Due to its shorter face-to-face distance compared to general check valves, it is most convenient for locations with installation space limitations.



Main Component Materials

NO.	Name	Material
1	Spring	Stainless Steel
2	Valve Stem	Stainless Steel
3	Valve seat	Rubber (NBR)
4	Valve disc	Stainless steel
5	Lever	Stainless steel covered with rubber
6	Valve Body	Cast Iron

Energy-saving Silent Check Valve

Product Overview

The H41X energy-saving silent check valve is used in water supply and drainage pipelines. The valve disc is guided by the central shaft at both the inlet and outlet ends, allowing flexible opening and closing, and can be installed horizontally or vertically. The valve disc is spring-loaded, and its rapid closing effectively eliminates water hammer, with good sealing performance and noiseless closure. It features advantages such as compact size, light weight, low fluid resistance, fatigue resistance, and long service life.



Main component materials

Model	Valve body	Sealing ring	Spring
H41X-10	Cast iron or stainless steel	Nitrile rubber (NBR)	1Cr18Ni9Ti
H41X-16	Cast iron or stainless steel	Nitrile rubber (NBR)	1Cr18Ni9Ti

Typical Installation Diagram

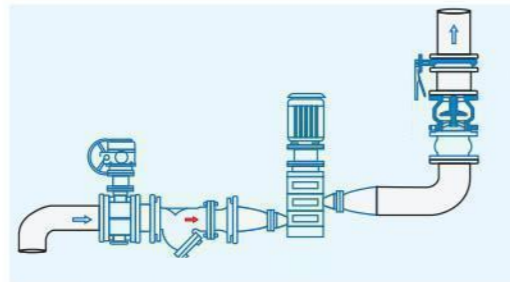

Technical Parameters

Nominal Pressure: 1.0~1.6 MPa
 Nominal Diameter: 40~600 mm
 Applicable Medium: Water and Weakly Corrosive Fluids
 Applicable Temperature: 0 ~ 80°C
 Flange standard: GB/T17241.6GB/T9113
 Test standard: GB/T13927API1598

Rubber Flap Check Valve

Product Overview

The H44X (SFCV) rubber flap check valve primarily consists of three main components: the valve body, valve cover, and rubber flap. The rubber flap uses steel plate, steel rod, and reinforced nylon fabric as the substrate, with an outer layer coated in rubber, achieving a service life of up to 1 million open-close cycles. This valve features a full-flow area design, offering low head loss, minimal debris accumulation, and easy maintenance. It is mainly suitable for water supply and drainage systems and can be installed at the outlet of water pumps to prevent backflow and water hammer damage to the pump. The valve can also be installed on the bypass pipe of the inlet and outlet pipes of water storage tanks to prevent tank water from flowing back into the water system.



Typical installation diagram

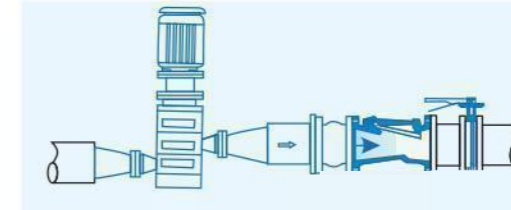

Technical Parameters

Nominal Pressure: 1.0~1.6 MPa
 Nominal Diameter: 50~600 mm
 Applicable Media: Water and Weakly Corrosive Fluids
 Applicable Temperature: 0~80°C
 Flange Standard: GB/T17241.6 GB/T9113
 Test standards: GB/T13927, API1598

Material of main components

Part name	Valve body	Valve cover	Valve disc
Material	Cast iron	Cast iron	Steel + reinforced nylon fabric

Slideway Ball Check Valve

Product Overview

The HQ41X slideway ball check valve uses a rubber-coated rolling ball as the valve disc. Under the action of the medium, it can roll up and down on the integrated slideway inside the valve body to open or close the valve, featuring good sealing performance, noise-reducing closure, and no water hammer. The valve body adopts a full water flow passage, providing large flow, low resistance, and a head loss 50% less than that of swing check valves. It can be installed horizontally or vertically, suitable for cold water, hot water, industrial and domestic sewage pipelines, and is particularly suitable for submersible sewage pumps. The medium temperature range is 0-80°C.



Typical Installation Diagram

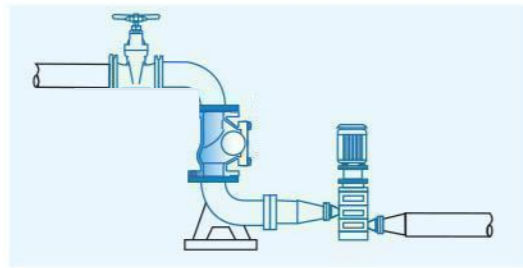

Technical Parameters

- Nominal pressure: 1.0-1.6 MPa
- Nominal diameter: 50-350 mm
- Applicable medium: Water and weakly corrosive fluids
- Applicable temperature: 0-80°C
- Flange standard: GB/T17241.6 GB/T9113
- Test standard: GB/T13927 AP11598

Main Component Materials

Part Name	Valve Body	Ball
Material	Cast Iron, Ductile Iron, Cast Steel	Steel body rubber-coated

Low-resistance spherical check valve

Product Overview

The HQ44/45X low-resistance spherical check valve uses a rubber-coated ball as the valve disc, which rolls along the slide track inside the valve body under medium pressure to open or close the valve. It features large flow capacity, minimal flow resistance loss, excellent sealing performance, and noise-reducing closure, helping to reduce water hammer. Suitable for horizontal or vertical installation. It can be used at pump outlets in pipelines for cold water, hot water, industrial wastewater, and domestic sewage to prevent backflow of the medium.



Typical Installation Diagram

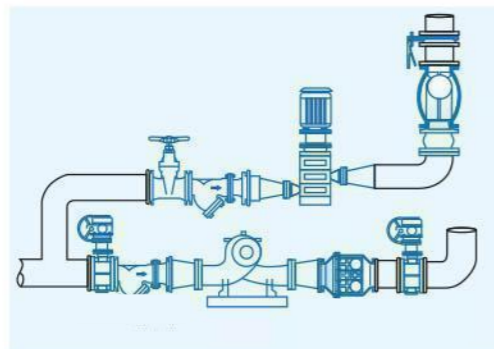

Technical Parameters

- Nominal Pressure: 1.0-1.6 MPa
- Nominal Diameter: 50-1000 mm
- Applicable Medium: Water and Weakly Corrosive Fluids
- Applicable Temperature: 0-80°C
- Flange standard: GB/T17241.6 GB/T9113
- Test standard: GB/T13927 AP11598

Main component materials

Part name	Valve body	Valve disc	Spring	Valve seat
Material	Cast iron, ductile iron, cast steel	Cast copper, stainless steel	Stainless steel	Copper, stainless steel

Proportional pressure reducing valve

Product Overview

The YB43X proportional pressure reducing valve features an attractive appearance and reliable quality. It provides accurate proportioning, stable operation, and reduces both dynamic and static pressure.

This valve uses the pressure differential force generated by the different cross-sectional areas at both ends of the internal piston to alter the downstream pressure, achieving the purpose of pressure reduction.

The reduction ratios are: 2:1, 3:1, 4:1, 3:2, 5:2, etc. Pressure reducing valves with special ratios can also be designed according to user requirements.

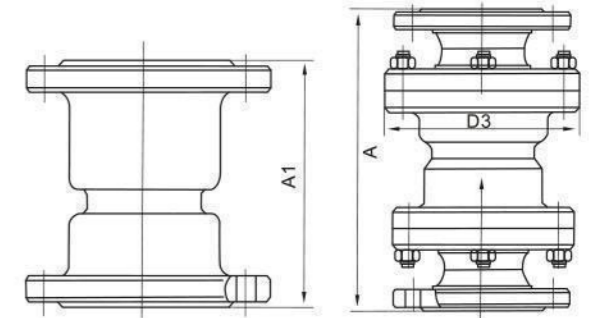

Main technical parameters

Main technical parameters	Water, gas		
Applicable Medium	≤ 90°C		
Applicable Temperature	≤ 8°C		
Pressure Error	0.2MPa		
Minimum Opening Pressure	0.3MPa		
Connection type	Flange, internal thread		
Main component material	Valve body	Tin bronze	Cast iron
	Internal parts	Stainless steel	Tin bronze or stainless steel

Main external connection dimensions

Unit: mm

DN (mm)	A1	A	D3
25	115	232	115/125
32	124	246	140/150
40	132	256	150/155
50	140	270	165/175
65	155	306	185/200
80	155	320	210/230
100	200	340	240/265
125	220	400	275/300
150	230	429	310/350
200	270	358	355/400

Pressure Reducing Valve

Product Overview

The Y42X pressure reducing valve is a pressure regulating valve that uses a piston instead of a diaphragm, increasing its lifespan by more than three times compared to diaphragm types. For sizes smaller than DN50, it is recommended to choose diaphragm-type reducing valves Y110 and Y116 (threaded connection); for sizes DN50 and larger, the piston-type reducing valve Y42X (flange connection) is suggested. This valve is an adjustable high-type pressure reducing valve, allowing the downstream pressure to be set as needed. Once in operation, the downstream pressure consistently reduces to and stabilizes at the set value, unaffected by upstream pressure or flow fluctuations. It features high-quality materials, reliable performance, and a long service life.

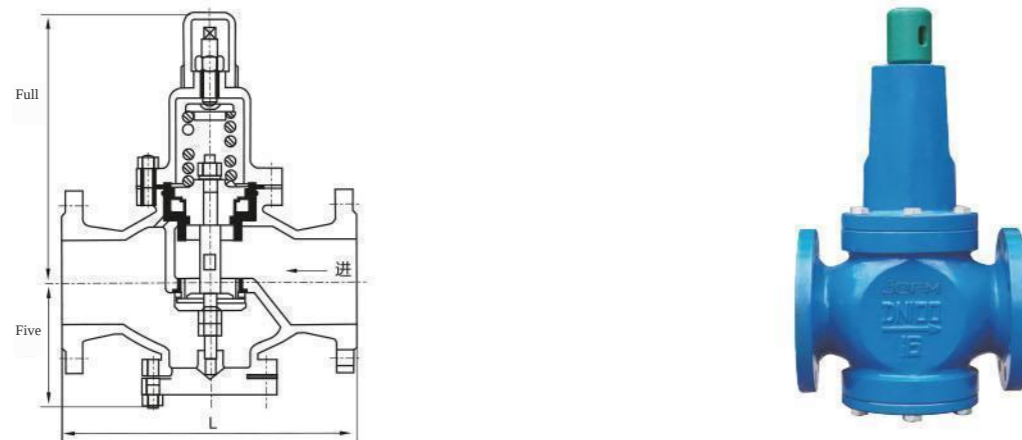

Technical Parameters

Nominal Pressure: 1.6-6.4 MPa

Nominal Diameter: 20-400 mm

Applicable Medium: Air or non-corrosive liquids

Applicable Temperature: 0 - 90°C

Flange Standard: GB/T17241.6 GB/T9113

Test standard: GB/T13927 API598

Part name	Material
Valve body, upper cover, lower cover	Cast iron, ductile iron, cast steel
Adjusting spring	Silicon manganese steel
Piston	Stainless steel
Cylinder liner	Stainless steel

Main external connection dimensions

Unit: mm

DN	L				H1				H2			
	PN16,25	PN40	PN64	PN16	PN25	PN40	PN64	PN16	PN25	PN40	PN64	
20	160	160	170	90	90	90	90	220	220	220	220	
25	180	200	200	95	95	100	105	255	255	265	265	
32	200	220	220	100	100	100	110	255	255	265	265	
40	220	240	240	115	115	130	130	325	325	330	330	
50	250	270	270	120	120	135	135	325	325	330	330	
65	260	280	300	125	125	130	145	330	330	340	355	
80	310	330	330	135	135	150	160	340	340	340	360	
100	350	380	380	108	108	185	185	317	317	360	360	
125	400	450	450	190	200	200	245	560	560	565	565	
150	450	500	500	205	210	240	280	580	580	585	585	
200	500	560	560	220	245	245	310	630	630	635	635	
250	600			270				750				
300	800			310				780				
350	850			390				850				
400	900			420				925				

Triple-Function Valve

Product Overview

The DYH41X Triple-Function Valve integrates silent check, flow regulation, and shut-off functions into one unit, allowing optimal flow adjustment for the system. This valve saves on installation costs, space, and time.

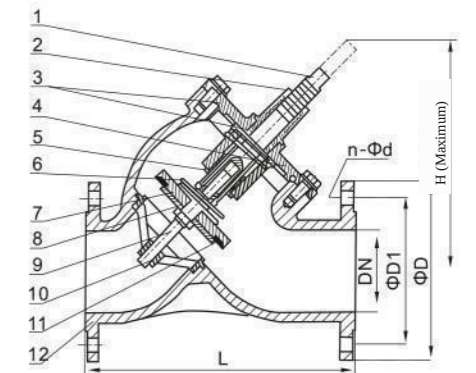

Typical Installation Diagram

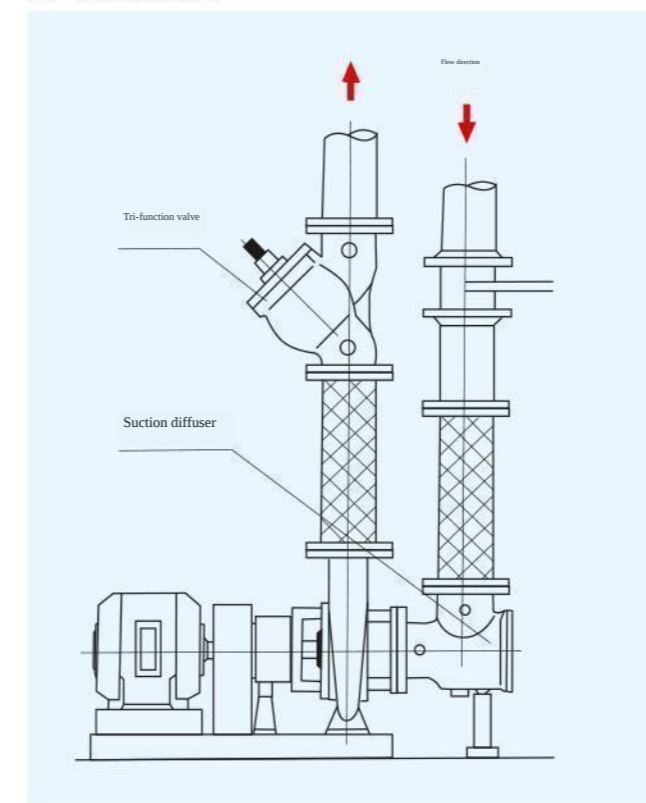

Main component materials

No.	Name	Material	Standard
1	Valve stem	Stainless steel	AISI304
2	Setting scale	Aluminum bronze	ASTM C61900
3	Sealing ring	Nitrile copper	NBR
4	Cover	Ductile iron, carbon steel	ASTMA536
5	Nut	Aluminum bronze	ASTMC61900
6	Spring	Stainless Steel	AISI304
7	Disc	Aluminum Bronze, Ductile iron	ASTMC61900/ASTMA536
8	Sealing ring	Nitrile rubber	NBR
9	Shaft	Stainless steel	AISI304
10	Valve seat	Aluminum bronze	ASTMC61900
11	Gasket	Nitrile Rubber	NBR
12	Valve Body	Ductile Iron, Carbon Steel	ASTMA536

Main Outline Connection Dimensions

Unit: mm

DN	D	ΦD1		n-Φd		L	H
		1.0MPa	1.6MPa	1.0MPa	1.6MPa		
50	165	125		4-19		230	196
65	185	145		4-19		290	221
80	200	160		8-19		310	244
100	220	180		8-19		350	268
125	250	210		8-19		350	296
150	285	240		8-23		480	338
200	340	295		8-23	12-23	600	421
250	405	350	355	12-23	12-28	730	492
300	460	400	410	12-23	12-28	730	552
350	520	460	470	16-23	16-28	980	645

Suction Diffuser

Product Overview

The suction diffuser is designed for direct installation at the pump's suction end. Its specialized filter configuration effectively removes debris, while the straight flow-straightening plate ensures smooth water flow to the pump, reducing turbulence impact and cavitation. It eliminates the need for a pump inlet guide pipe, significantly saving installation space, and can replace 90° elbows, Y-strainers, and flow-straightening pipes. It is primarily suitable for building, water supply, and HVAC systems.

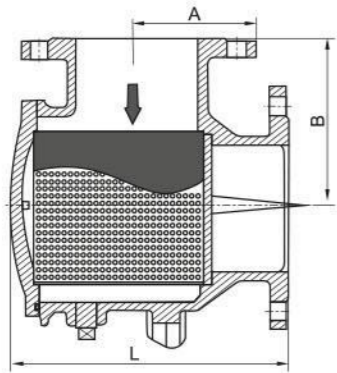

Main Component Materials

No.	Name	Material
1	Valve body	Ductile iron or welded stainless steel
2	Valve cover	Ductile iron or welded stainless steel
3	Flow straightener	Ductile iron or welded stainless steel
4	Filter screen	Stainless steel
5	Filter cover	Stainless steel
6	Bolt	Galvanized steel or stainless steel
7	Washer	Zinc-plated steel or stainless steel
8	Sealing ring	Nitrile rubber
9	Screw plug	Zinc-plated steel or stainless steel
10	Support Base	Ductile Iron Coated with Epoxy Resin
11	Nut	Steel Galvanized or Stainless Steel
12	Support Bolt	Steel Galvanized or Stainless Steel

Typical Installation Diagram

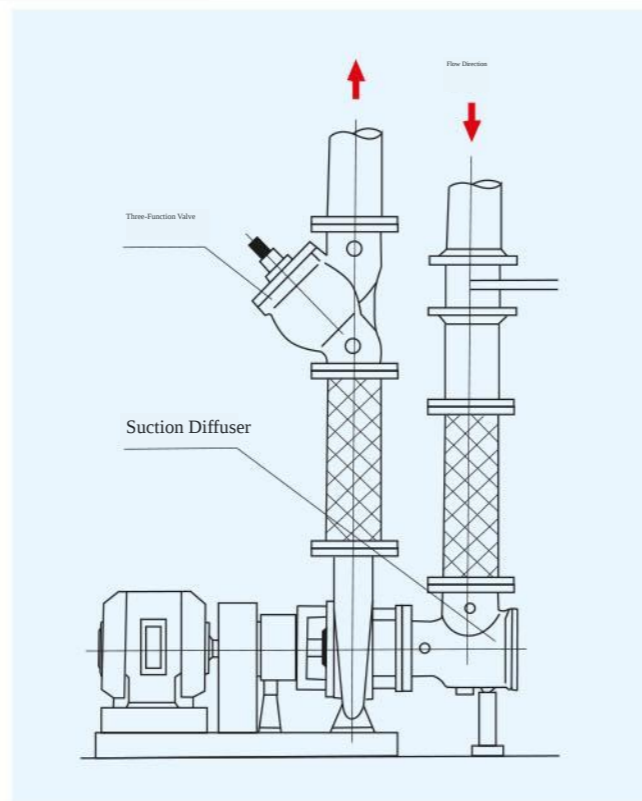

Technical Specifications

Size Range: DN50mm to DN600mm

Pressure rating: 1.0MPa~2.5MPa

Temperature range: -10°C~120°C

Applicable media: clean water, wastewater

Main external dimensions

DN	50	65	80	100	125	150	200	250	300	350	400	450	500	600
L	200	210	240	250	290	320	410	450	510	570	640	730	805	940
A	95	110	135	150	155	170	230	250	275	315	360	400	460	560
B	105	115	140	150	155	170	245	250	275	315	360	400	470	580

Quick-opening sludge discharge valve

Product overview

The JM744X and JM644X quick-opening drain valves are angular shut-off valves driven by hydraulic or pneumatic actuators. They are typically installed in rows on the outer bottom walls of sedimentation tanks to discharge settled sludge, sand, and debris. The valve is divided into two chambers by a nylon-reinforced rubber diaphragm. By connecting to a hydraulic or pneumatic source and controlling it with an electric or manual two-position four-way directional valve, rapid sludge discharge is achieved. The valve uses a diaphragm instead of a piston, eliminating moving friction, making it more suitable for granular media like slurry, and significantly extending the valve's service life.

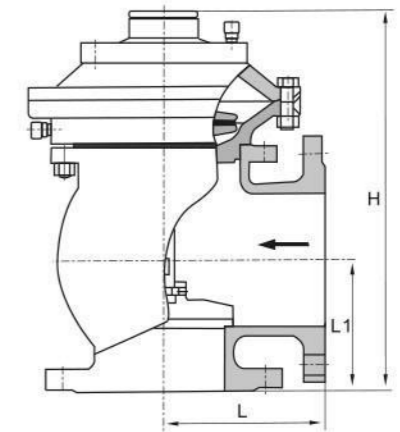

Typical installation diagram

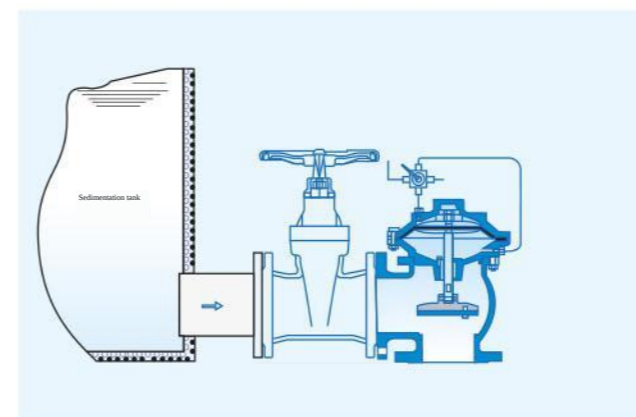

Technical parameters

Nominal pressure: 0.6-1.0 MPa

Nominal diameter: 100-400 mm

Minimum driving pressure: 0.15 MPa

Applicable media: water, sewage

Driving media: clean water, air

Applicable temperature: 0 – 80°C

Flange standard: GB/T17241.6 GB/T9113

Test standard: GB/T13927 API598

Main Component Materials

Part Name	Valve Body, Valve Cover	Diaphragm Pressure Plate, Valve Disc	Valve Stem	Diaphragm
Material	Cast iron, ductile iron, carbon steel	Ductile iron, bronze	Stainless steel	Nylon-reinforced rubber

Main external connection dimensions

Unit: mm

DN	100	150	200	250	300	350	400
L	160	190	225	260	280	315	340
L1	120	150	190	220	260	300	340
H	370	440	530	615	785	880	970

Hydraulic/Pneumatic Angle Type Quick-Opening Mud Drain Valve

Product Overview

The J744X/J644X hydraulic and pneumatic angle type quick-opening mud drain valve is an angle-type stop valve actuated by a hydraulic or pneumatic power source. It is typically installed in rows on the outer wall at the bottom of sedimentation tanks to discharge settled sludge, sand, and debris. The valve features an L-shaped cup piston in its hydraulic cylinder, offering excellent sealing performance and durability. The valve sealing pair also employs rubber sealing for leak-free operation. Remote control can be achieved via an electric two-position four-way directional solenoid valve. It is easy to operate, safe, and reliable.

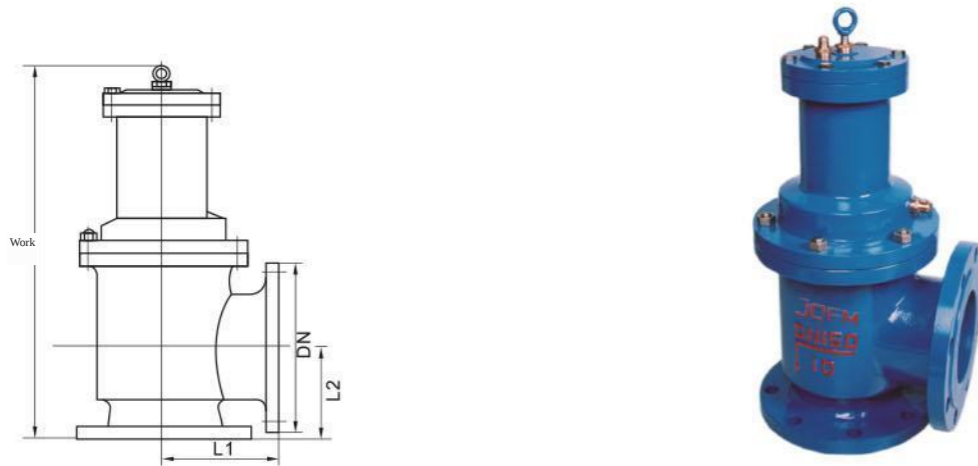

Typical Installation Diagram

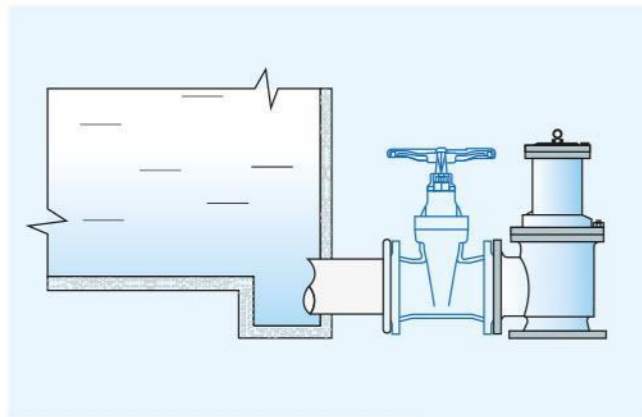

Technical Parameters

Nominal Pressure: 0.6-1.0 MPa
 Nominal Diameter: 80-400 mm
 Minimum Drive Pressure: 0.15 MPa
 Applicable medium: Water, sewage
 Driving medium: Clean water, air
 Applicable temperature: 0 – 80°C
 Flange standard: GB/T 17241.6 GB/T 9113
 Test standard: GB/T 13927 API598

Main component materials

Part Name	Valve Body, Valve Cover	Diaphragm Pressure Plate, Valve Disc	Valve Stem	Diaphragm
Material	Cast iron, ductile iron, carbon steel	Ductile iron, bronze	Stainless steel	Nylon-reinforced rubber

Main external connection dimensions

Unit: mm

DN	80	100	150	200	250	300	350	400
L	480	500	620	735	805	940	1100	1200
L1	135	145	175	225	260	280	305	340
H	125	125	145	185	205	245	270	310

Type Pneumatic and Hydraulic Tank Bottom Sludge Discharge Valve

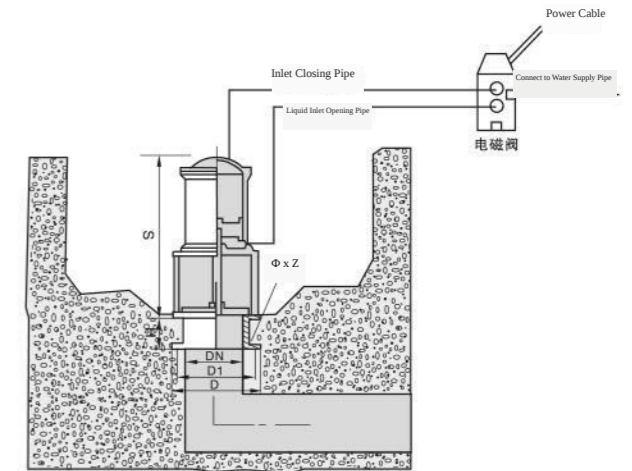

Purpose

This product is used by water supply companies or other companies to remove sediment from various types of pools.

Working Principle and Performance

The valve consists of a valve body, hydraulic cylinder, piston, valve stem, and valve disc, with the hydraulic cylinder serving as the liquid tool. Using liquid as the power source, the piston and valve stem act as the switch. It takes only one minute to open the valve plate. This valve must be paired with a manual switching method or an electromagnetic device for remote control of the sludge discharge valve. The valve features strong sealing performance, flexible operation, easy maintenance, and a long service life, lasting over five years, with an 18-month warranty. Note: Use air or clean water as the driving fluid.

Technical Parameters

Working Pressure	1.0MPa
Medium	Water
Operating temperature	Room temperature
Hydraulic cylinder working pressure	0.3-1.0
Hydraulic cylinder working fluid	Air, clean water

Main component materials

Valve body	HT200
Hydraulic cylinder	HT200, 304 stainless steel
Cylinder head	HT200
Valve plate	HT200
Valve stem	Stainless steel
Sealing cup	Wear-resistant nitrile rubber

Overall Dimensions Table

Nominal Diameter DN(mm)	Dimensions (mm)					Inlet Connection G	Stem Material
	D	D1	ΦXZ	S	H		
150	280	240	23x8	490	130	1/2	Stainless steel
200	335	295	23x8	530	140	1/2	Stainless steel
250	390	350	23x12	570	150	1/2	Stainless steel
300	440	400	23x12	610	160	1/2	Stainless steel
350	510	460	25x16	350	170	1/2	Stainless steel
400	565	515	25x16	710	180	1/2	Stainless steel

Isolated Pool Bottom Sludge Discharge Valve

Manual Sludge Discharge Valve

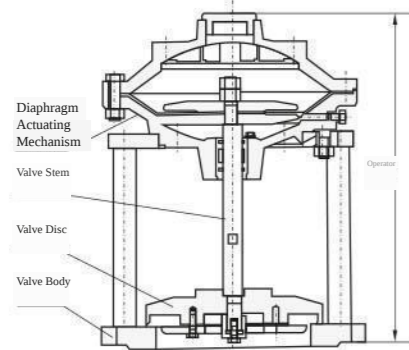

Purpose

This product is used by water supply companies or other companies for various tanks to remove sediment from the tank.

Working Principle and Performance

The valve consists of a valve body, upper and lower diaphragm chambers, a diaphragm, and a valve stem. The upper and lower diaphragm chambers serve as liquid tools. Using liquid as the power source, the diaphragm and valve stem act as the switch, allowing the valve plate to open in just one minute. This valve must be paired with a manual switching method or an electromagnetic device for remote control of the sludge discharge valve. The valve features strong sealing performance, flexible operation, easy maintenance, and a long service life, with a lifespan of over five years and a warranty period of eighteen months.

Technical Parameters

Working Pressure	1.0 MPa
Medium	Water
Operating Temperature	Ambient Temperature
Diaphragm Chamber Working Pressure	0.3-1.0
Diaphragm chamber working fluid	Gas, clean water

Typical installation diagram

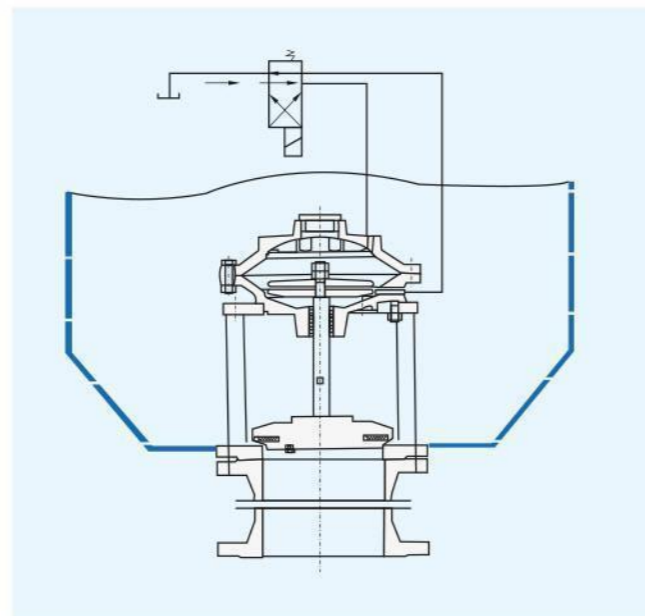

Main component materials

Valve body	HT200
Upper diaphragm chamber	HT200
Subdiaphragmatic cavity	HT200
Valve plate	HT200
Valve stem	Stainless steel
Assembly cap	A3 steel
Diaphragm	Nitrile wear-resistant rubber and nylon

Main external connection dimensions (flange connection dimensions according to JB/T97-94)

Unit: mm

Flange connection dimensions according to JB/T97-94	DN	100	150	200	250	300	350	400
	H	260	375	430	525	585	600	680

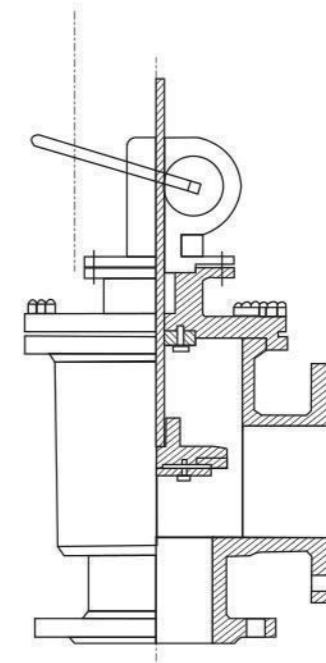

Application

This product is used by water supply companies or other enterprises to remove sediment from various types of pools.

Working Principle and Performance

This valve is essentially the same as the J744X mud discharge valve. Its rotation is driven by gears and a rack, allowing for convenient and rapid lifting and lowering, simple maintenance, a service life of over five years, and a warranty period of eighteen months.

Technical Parameters

Working pressure	1.0MPa
Medium	Water
Operating temperature	Ambient temperature

Main Component Materials

Valve Body	HT200
Valve Frame	HT200
Gear Frame	HT200
Valve Stem	Stainless Steel
Gear	Carbon steel

External connection dimensions

Unit: mm

Specification DN (mm)	Dimensions (mm)	D	D1	Φ	L	H1	H	Z-Φd	Inlet Connection G
80		195	160	210	135	115	330	4X18	1/2
100		215	180	240	145	125	360	8x18	1/2
150		280	240	315	185	155	450	8x23	1/2
200		335	290	400	220	185	545	8x23	1/2
250		390	350	460	250	215	610	12x23	1/2
300		440	400	555	280	240	680	12X23	1/2

Reunion Ceremony Exhaust Valve

Product Overview

The SCAR compound exhaust valve features a cylindrical valve body, with internal components including a stainless steel float ball, valve stem, and valve disc. Installed at the pump outlet or in water distribution pipelines, it is used to expel accumulated air in the pipe. When negative pressure occurs inside the pipe, the valve quickly draws in external air to prevent pipeline damage due to the negative pressure. During initial water filling, the valve disc remains open to allow massive exhaust; once exhausted, the valve fills with water, the float ball rises to close the disc, stopping exhaust. During normal water conveyance, minor air accumulates, and as the water level drops, air is expelled through small holes. When the pump stops, causing the pipe to empty or experience negative pressure, the plug promptly opens to admit air, ensuring pipeline safety.

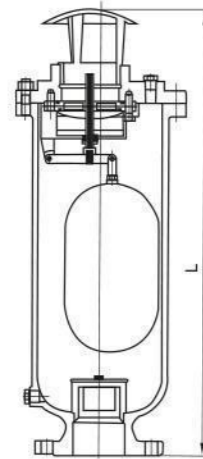

Typical Installation Diagram

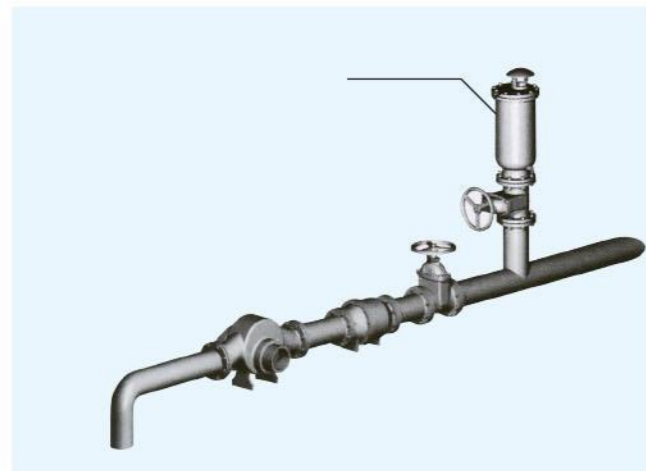

Technical Parameters

Nominal Pressure: 1.6 MPa
Nominal Diameter: DN50-200mm with Flange Connection
Applicable Media: Water, Sewage
Applicable temperature: 0 – 100°C

Main component materials

No.	Name	Material
1	Valve body	Ductile iron, cast iron
2	Valve Cover	Ductile Iron, Cast Iron
3	Float Ball	Stainless Steel
4	Lever Bracket	Stainless Steel
5	Lever	Aluminum Bronze
6	Plug	Aluminum Bronze

Main Outline Connection Dimensions Unit: mm

Product Code	DN	L
SCAR	50	590
SCAR	80	680
SCAR	100	760
SCAR	150	900
SCAR	200	918

Combined Air Release Valve

Product Overview

The CARX composite air valve body is cylindrical, with internal components including a stainless steel float, lever, and valve disc. Installed at pump outlets or in water distribution pipelines, it expels accumulated air in the pipes to enhance pipeline and pump efficiency. When negative pressure occurs in the pipe, it rapidly draws in external air to prevent pipeline damage from vacuum. During initial water filling, the valve disc remains open for substantial air release. Once air is fully expelled and the valve fills with water, the float rises and closes the valve disc, stopping air discharge. During normal water transport, if minor air accumulates to a significant level, the water level in the valve drops, allowing air to escape through a small orifice. When the pump stops, causing the pipe to drain or generate negative pressure, the plug opens swiftly to admit air, ensuring pipeline safety.



Typical Installation Diagram

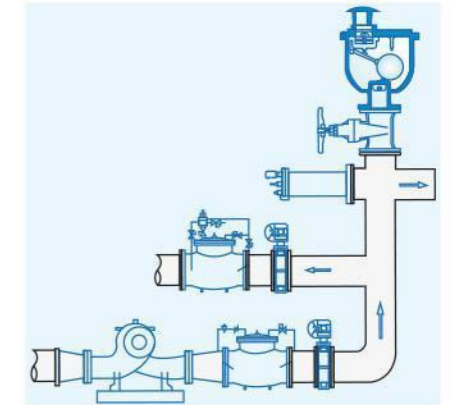

Main Component Materials

NO.	1	2	3	4	5	6
Name	Valve Body	Valve Cover	Float ball	Lever bracket	Lever	Plug
Material	Ductile iron, cast iron	Ductile iron, cast iron	Stainless steel	Stainless steel	Aluminum bronze	Aluminum bronze

Technical parameters

Nominal pressure: 1.0-1.6MPa
Nominal diameter: DN25-32mm for threaded connection, DN50-200mm for flange connection
Applicable medium: Water, oil, and other non-corrosive liquids
Applicable temperature: 0 – 100°C

Combined Air Release Valve

Main Component Materials

Valve Body	Ductile Iron
Valve Cover	Ductile Iron
Dust Cover	Ductile Iron
Float Body	Stainless Steel
Sealing Surface	Nitrile rubber



Main performance specifications

Nominal pressure		PN10	PN16	MPa
Test pressure	Shell strength	1.5	2.4	
	Liquid High-Pressure Seal	1.1	1.76	
Medium Temperature		-10 to 80°C		
Applicable Medium		Water, etc.		

quick exhaust valve/ARVX micro exhaust valve

Product Overview

The P41X and P42X quick exhaust valves are suitable for water pipelines to improve the efficiency of water conveyance equipment and protect pipelines from deformation and rupture, making them essential pipeline equipment. They can expel gas from pipelines, reduce resistance, and save energy. When negative pressure occurs in the pipeline, they quickly and automatically draw in air to prevent pipeline rupture. Their exhaust capacity is multiple times that of ordinary double-orifice exhaust valves. These valves are installed at pump outlets or in water distribution pipelines to remove large amounts of accumulated air from the pipelines, enhancing the efficiency of water pipes and pumps. Moreover, if negative pressure occurs in the pipeline, these valves rapidly draw in air to prevent damage caused by negative pressure. The ARVX micro exhaust valve primarily addresses the approximately 2VOL% of dissolved air in water, which is continuously released during water conveyance, accumulating at high points in the pipeline to form air pockets. This makes water conveyance difficult and reduces the system's water conveyance capacity by about 5-15%. The main function of the micro exhaust valve is to expel the 2VOL% dissolved air. It is suitable for installation in high-rise buildings and small pumping stations to protect or improve the system's water conveyance efficiency and save energy.



Quick exhaust valve



Micro exhaust valve

Technical parameters

Nominal pressure: 1.0-1.6 MPa
Nominal diameter: DN25-200 mm
Applicable medium: Water, oil, and other non-corrosive liquids
Applicable temperature: 0 – 100°C

Main component materials

Name	Material
Valve Body	Ductile Iron, Cast Iron
Valve Cover	Ductile Iron, Cast Iron
Float Ball	Stainless steel
Lever bracket	Stainless steel
Lever	Aluminum bronze
Plug	Aluminum Bronze

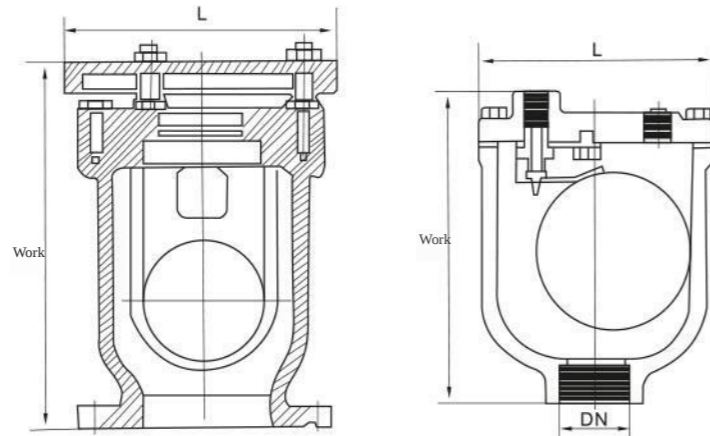

Main External Connection Dimensions

DN	L	H
25	150	240
50	165	270
80	200	300
100	220	335
150	290	430
200	340	505

Main External Connection Dimensions Unit: mm

DN	L	H
10	102	127
15	102	127
20	102	127
25	102	127

Y-Strainer, Y-Type Expansion Strainer

Product Overview

The Y-type filter features a double-layer reinforced screen, used in water supply systems for buildings, industrial, and other water applications to filter impurities, ensuring normal water quality in the system and preventing clogging failures in valves or equipment within the pipeline.

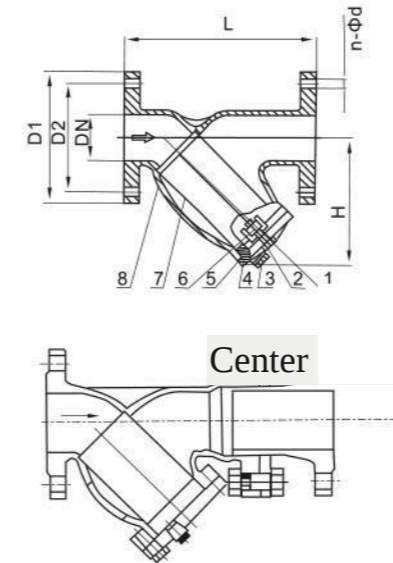

Main Component Materials

No.	Name	Material	Standard
1	Bolt	Carbon Steel	Standard Part/AISI304
2	Washer	Nitrile Rubber	Standard Part/AISI304
3	Drain plug	Carbon steel, stainless steel	Standard parts/AISI304
4	Valve cover	Ductile iron, carbon steel	ASTMA536
5	Sealing ring	Nitrile rubber	NBR
6	Nut	Carbon steel	Standard part/AISI304
7	Filter screen	Stainless steel	AISI304
8	Valve Body	Ductile Iron, Carbon Steel	ASTMA536

Main External Connection Dimensions

Unit: mm

NO.	L		H	D1		D2		n-Φd	
	SY4P	YSTF		1.0 MPa	1.6 MPa	1.0 MPa	1.6 MPa	1.0 MPa	1.6 MPa
50	230	300	155	165		125		4-19	
65	250	320	183	185		145		4-19	
80	280	380	210	200		160		8-19	
100	350	430	250	220		180		8-19	
125	400	500	305	250		210		8-19	
150	440	550	358	285		240		8-23	
200	500	650	450	340		295		8-23	12-23
250	580	775	503	405	350	355		12-23	12-28
300	670	900	578	460	400	410		12-23	12-28
350	780	1025	598	520	460	470		16-23	16-28
400	850	1150	618	580	525	525		16-26	16-30

Backflow Preventer

Product Overview

The DF41/HS41 backflow preventer (anti-pollution shut-off valve) consists of two separated check valves and a hydraulically actuated drain valve, with the first check valve containing a filter screen. Due to the local head loss in the check valves, the pressure in the intermediate chamber is always lower than that at the inlet. This pressure differential keeps the drain valve in a closed state, allowing normal pipeline water supply. Under abnormal pressure conditions (i.e., when the outlet pressure exceeds the intermediate chamber pressure), even if both check valves fail to seal in reverse, the safety drain valve automatically opens to discharge backflow water and create an air gap, ensuring the sanitary safety of the upstream water supply.

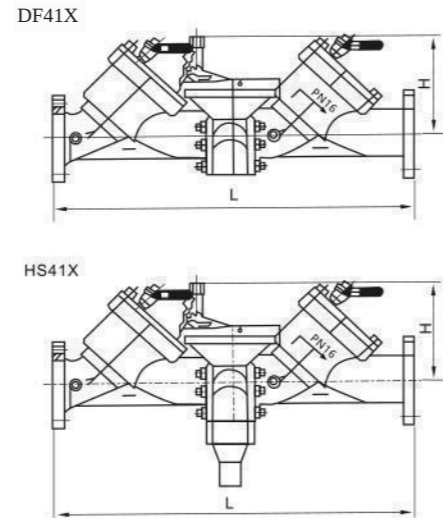

Typical Installation Diagram

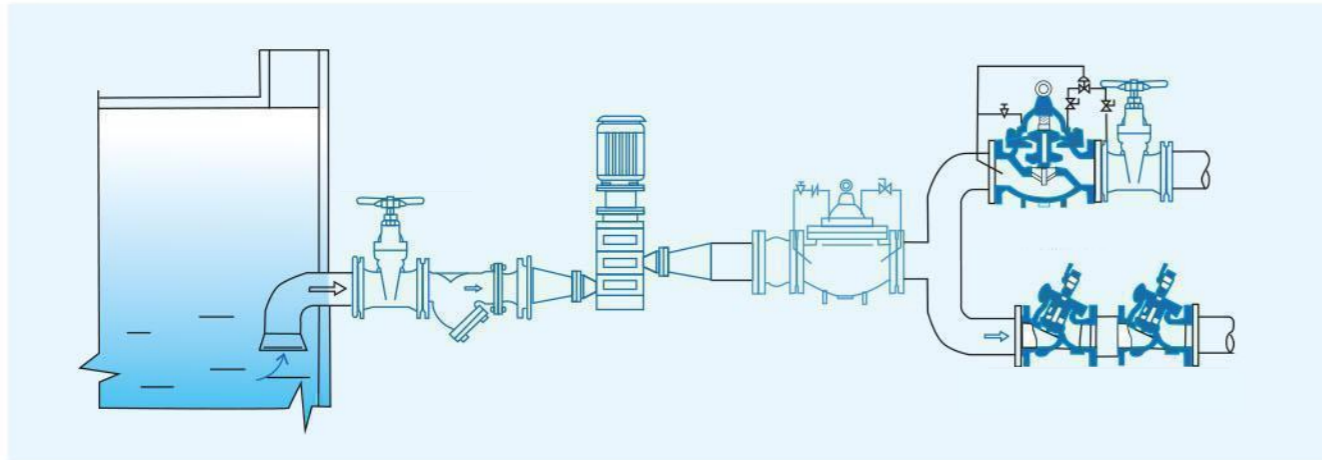

Main external connection dimensions ^{Unit: mm}

Model	DN	L	H
		1.0/1.6MPa	1.0/1.6MPa
DF41/HS41	40	470	320
DF41/HS41	50	470	320
DF41/HS41	65	560	400
DF41/HS41	80	560	400
DF41/HS41	100	700	440
DF41/HS41	125	705	550
DF41/HS41	150	870	550
DF41/HS41	200	1000	600
DF41/HS41	250	1120	750
DF41/HS41	300	1200	900
DF41/HS41	350	1380	900

Main Component Materials

Name	Material
Valve Body	Cast Iron, Ductile Iron
Valve Cover	Cast iron, ductile iron
Valve disc	Ductile iron
Spring	Stainless steel
Drain valve	Brass

Balancing Valve

Product Overview

The KPF balancing valve is a regulating valve with special functions, featuring excellent flow characteristics. It can reasonably distribute flow, achieve flow quantification, and effectively address uneven room temperature issues in heating (air conditioning) systems. Equipped with opening degree indication, an opening locking device, and a pressure measurement port for flow determination, this valve allows for proper installation of appropriately sized balancing valves at each branch and user inlet. After a one-time adjustment and lock using dedicated intelligent instruments, the system's total water flow is controlled within a reasonable range, thereby overcoming the irrational phenomenon of "high flow, low temperature difference."

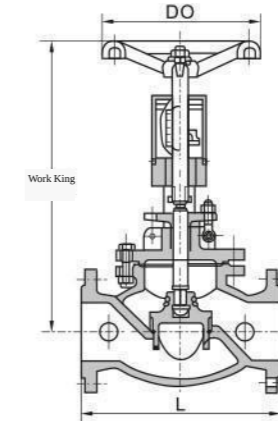
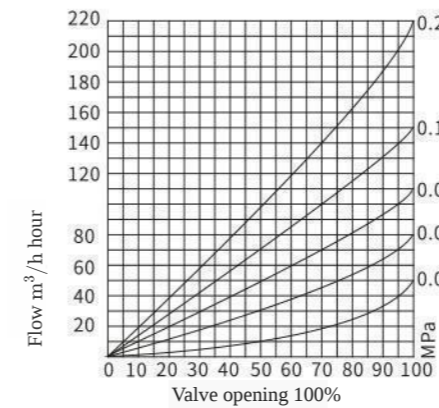

Typical installation diagram

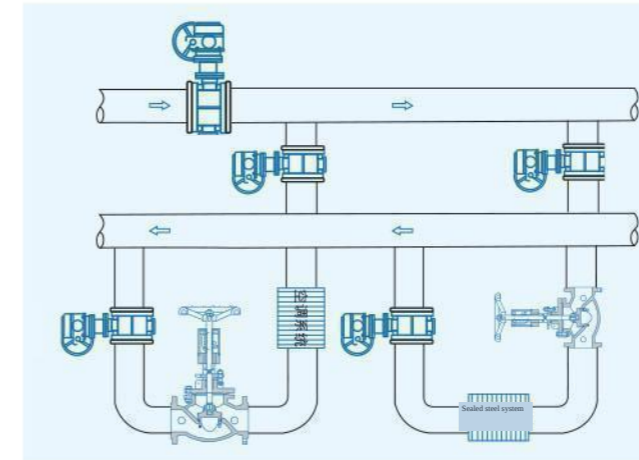

Technical parameters

Nominal pressure: 1.6 MPa
 Nominal diameter: 15–600 mm
 Applicable medium: Water, oil, and other non-corrosive liquids
 Applicable temperature: 0 ~ 100°C
 Flange standard: GB/T17241.6 GB/T9113
 Test standard: GB/T13927 API598

Main Component Materials

Part Name	Valve Body, Bonnet, Disc, Gland	Stem, Seal Valve	Stem, Nut	Gasket	Filler
Material	Gray cast iron, cast steel	Stainless steel	Cast steel	Nitrile rubber	Expanded Graphite

Main Outline Connection Dimensions

Unit: mm

DN	15	20	25	32	40	50	65	80	100	125	150	200	250	300	350	400	500	600
L	130	150	160	180	200	230	290	310	350	400	480	495	622	698	787	914	978	1295
H1	150	160	182	192	250	264	380	413	446	540	623	687	782	914	968	1037	1440	1790
H2	160	170	197	207	270	284	410	448	506	595	688	762	867	1009	1073	1152	1440	1790
D0	80	180	80	90	100	120	200	200	240	240	360	400	500	500	680	680		

Digital Locking Balancing Valve

Product Overview

The SP45 and SP15F digital-locking balancing valves are regulating valves with a special digital-locking function, offering superior equal-percentage flow characteristics for rational flow distribution, effectively addressing uneven room temperatures in heating (air conditioning) systems. They precisely adjust pressure drop and flow to improve fluid dynamics in pipeline networks, achieving hydraulic balance and energy savings. The valves feature opening indicators, locking devices, and pressure taps for flow measurement. By installing appropriately sized balancing valves at each branch and user inlet, and performing a one-time adjustment and lock with dedicated smart instruments, the system's total water flow is kept within an optimal range, thereby eliminating the inefficient "high flow, low temperature difference" phenomenon. This product is an ideal solution for heating systems.

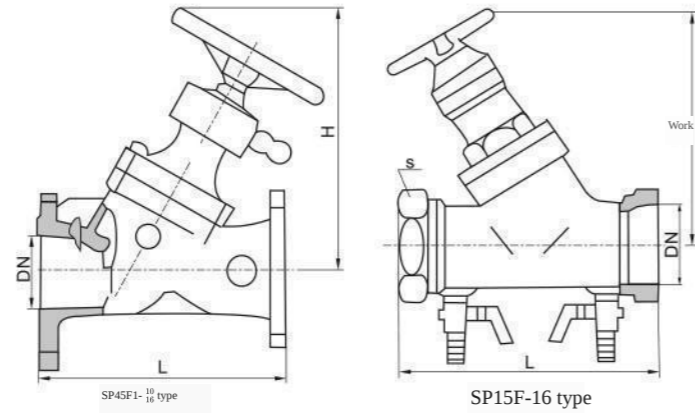

Typical installation diagram

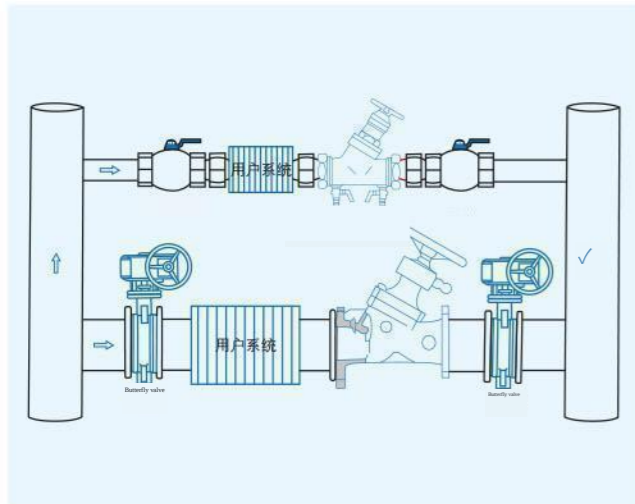

Technical parameters

Nominal pressure: 1.6 MPa (16 kgf/cm²)
 Applicable temperature: 0 ~ 100°C
 Applicable media: Water, oil, and other non-corrosive liquids
 法兰标准: GB/T17241.6 GB/T9113
 Test standards: GB/T13927 API598

Main component materials

Part name	Valve body, bonnet	Valve	Disc	Gasket
Material	Gray cast iron, ductile iron, cast steel	Stainless steel	Ductile cast iron	Rubber asbestos sheet

Main external connection dimensions

Unit: mm

SP4 5F type	DN	32	40	50	65	80	100	125	150	200	250	300	350	SP1 5F type	DN	15	20	25	32	40
	L	180	200	230	290	310	350	400	480	550	622	698	787		ZG	1/2"	3/4"	1"	5/4"	3/2"
H	230	242	250	260	329	340	424	454	517	573	617	705	L	100	115	125	140	160		
													H	128	128	130	150	187		

self-operated balancing valve

Product overview

The ZLF self-operated balancing valve is a type of valve that utilizes the pressure changes of the medium itself to self-regulate, thereby maintaining a constant flow rate through the controlled system. The ZLF self-operated balancing valve features flow indication, allows online adjustment, and is suitable for flow control of non-corrosive media such as heating and air conditioning systems. A one-time test adjustment before operation can automatically keep the system flow constant at a preset value. This valve offers accurate flow regulation, simple operation, stable performance, reliable functionality, and a long service life.

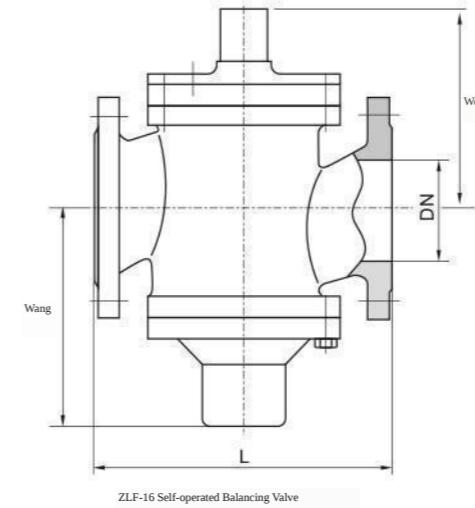

Typical Installation Diagram

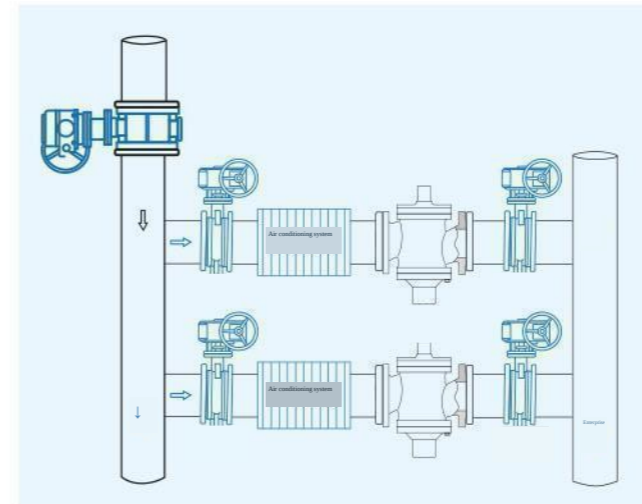

Technical Parameters

Nominal Pressure: 1.6 MPa
 Nominal Diameter: 15-350 mm
 Suitable media: water, oil, and other non-corrosive liquids
 Suitable temperature: 0 ~ 100°C
 Flange standard: GB/T17241.6 GB/T9113
 Test standard: GB/T13927 API598

Main component materials

Part name	Valve body, valve cover	Valve stem	Valve disc	Diaphragm
Material	Gray cast iron, ductile iron, cast steel	Stainless steel	Cast copper	Nitrile rubber

Main external connection dimensions

Unit: mm

DN	15	20	25	32	40	50	65	80	100	125	150	200	250	300	350
L	110	110	115	160	200	215	230	275	290	310	350	430	520	635	670
H1	72	72	81	108	138	138	143	170	193	208	254	289	325	357	372
H	70	70	74	91	147	147	154	189	211	227	260	303	367	430	495
Flow rate m ³ /h	0.1~1	0.1~1.5	0.2~2	0.5~4	1~6	2~10	3~15	5~25	10~35	15~50	30~80	40~180	100~130	150~500	200~700

Self-operated balancing valve

Product Overview

The ZL47F self-operated balancing valve is a type of valve that utilizes the pressure changes of the medium itself to self-regulate and maintain a balanced flow through the controlled system. The ZL47F self-operated balancing valve features flow indication, allows online adjustment, and is suitable for flow control of non-corrosive media such as heating and air conditioning systems. A one-time test adjustment before operation enables the system flow to automatically stabilize at a preset value. This valve offers accurate flow regulation, simple operation, smooth action, reliable performance, and a long service life.

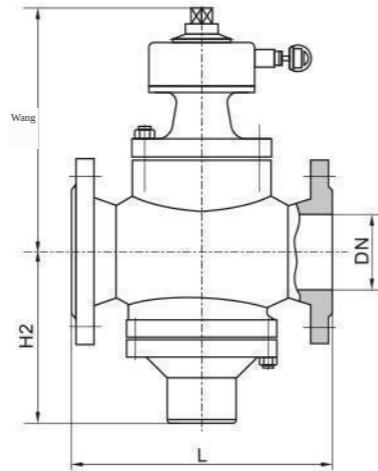

Typical Installation Diagram

Technical Specifications

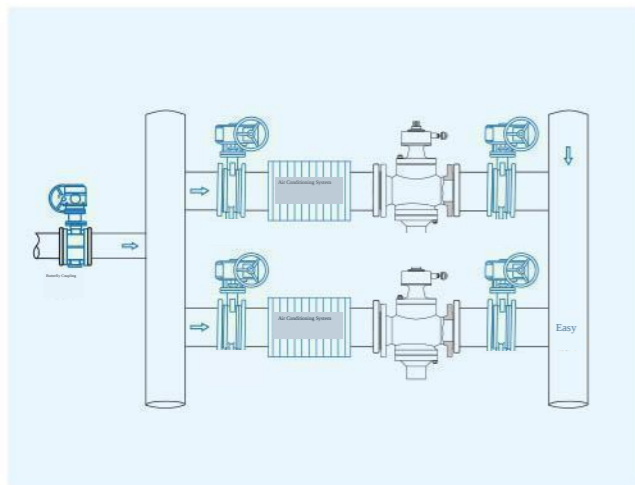

Nominal Pressure: 1.6 MPa
 Nominal Diameter: 15-400 mm
 Applicable Media: Water, oil, and other non-corrosive liquids
 Applicable Temperature: 0 ~ 100°C
 Flange Standard: GB/T 17241.6 GB/T 9113
 Test standards: GB/T13927 API598

Main Component Materials

Part Name	Valve Body, Valve Cover	Valve Stem	Valve Disc	Diaphragm
Material	Gray cast iron, cast steel	Stainless steel	Cast copper	Nitrile rubber

Main external connection dimensions

Unit: mm

DN	15	20	25	32	40	50	65	80	100	125	150	200	250	300	350	400
L	110	110	115	160	200	215	230	275	290	315	350	430	520	635	670	700
H1	122	122	137	182	191	197	205	259	268	337	257	407	452	486	534	534
H2	70	70	74	91	147	147	154	181	211	227	260	303	367	430	553	561

Self-operated differential pressure control valve

Product Overview

The ZYC self-operated differential pressure control valve is a type of valve that utilizes the pressure changes of the medium itself for self-regulation, maintaining a constant differential pressure of the medium flowing through the controlled system. It is suitable for differential pressure control in heating systems using a two-pipe setup, ensuring the system's differential pressure remains largely unchanged, reducing noise, balancing resistance, and eliminating thermal and hydraulic imbalances.

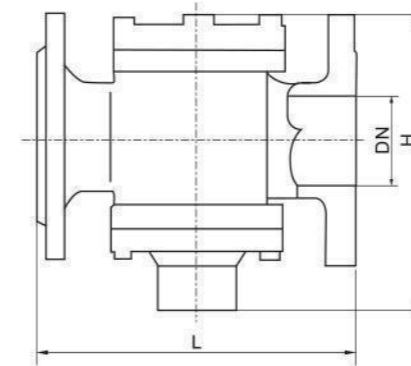

Typical installation diagram

Technical parameters

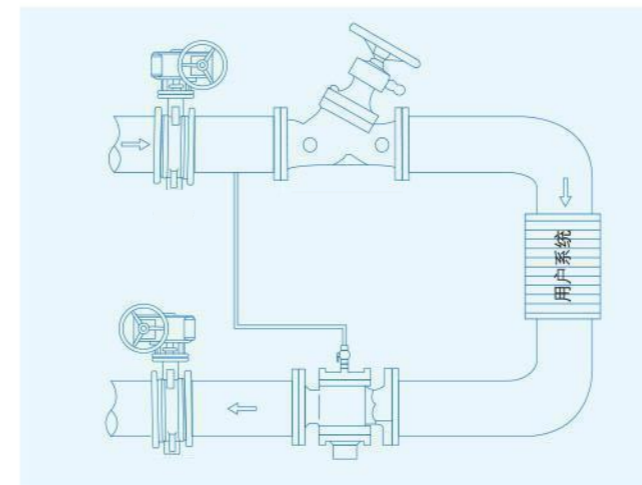

Nominal diameter: 15-125mm
 Nominal diameter: 15-125 mm
 Applicable medium: Water, oil, and other non-corrosive liquids
 Applicable temperature: 0 ~ 100°C
 Differential pressure control range: Fixed differential type 10 kPa, 20 kPa, 30 kPa
 Flange standard: GB/T17241.6 GB/T9113
 Test standard: GB/T13927 API598

Main component materials

Part name	Valve body, valve cover	Valve stem	Valve disc	Diaphragm
Material	Gray cast iron, cast steel	Stainless steel	Cast copper	Nitrile rubber

Main external connection dimensions

Unit: mm

DN	15	20	25	32	40	50	65	80	100	125
Connection	Thread						Flange			
L	110	110	115	130	200	215	230	275	290	310
H(mm)	95	110	130	140	190	205	240	300	350	380
Flow Rate m ² /h	0.2-1	0.3-1.5	0.5-2	1-4	1.5-6	2.8	3-12	5-20	10-30	15-45

Static Flow Balancing Valve

Product Overview

The central air conditioning static flow balancing valve is a flow regulating valve for liquid pipelines. Its function is to conveniently and accurately adjust the flow, effectively solving issues of uneven cooling/heating and hydraulic imbalance in pipeline systems. It can also be used as a shut-off valve. Maintains system flow balance, hydraulic stability, and uniform cooling/heating.

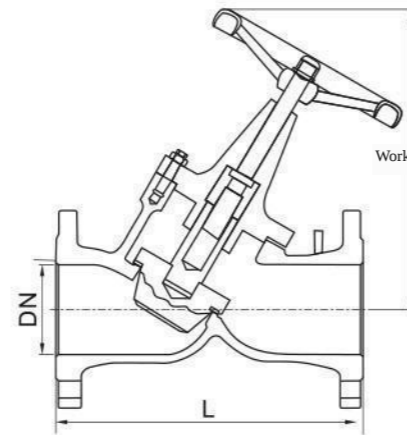

Product Features

Linear flow characteristics: large flow at high opening, small flow at low opening;

The valve body adopts a straight-through structure, resulting in low fluid resistance;

It features a percentage opening display; the product of the number of opening turns and the stem pitch gives the opening value.

Pressure measurement valves are provided at the inlet and outlet; when connected to an intelligent instrument via a hose, the pressure difference across the valve and the flow rate through it can be easily measured.

The sealing surface uses polytetrafluoroethylene, offering good sealing performance and long service life.

Working Principle

The central air conditioning static flow balancing valve is a liquid pipeline flow regulating valve, designed to conveniently and accurately adjust flow, effectively solving issues of uneven cooling/heating and hydraulic imbalance in pipeline systems. It not only offers excellent regulation performance but also features opening degree functionality and display, widely used in heating and air conditioning systems and other liquid pipeline systems requiring flow regulation. Equipped with a flow pressure measurement port, it allows one-time commissioning with intelligent instruments to control the total system water volume within a reasonable range, achieving pipeline balance and significant energy savings.

Technical Parameters

测试压力	1.6MPa
工作压力	1.0MPa
工作温度	0°C-120°C
适用介质	水、油和其它液体
流量误差	从100%开度到50%开度±5°C
适用范围	管网系统的主干、分支干、室内供水管、分支立管以及多台锅炉等

Typical installation diagram

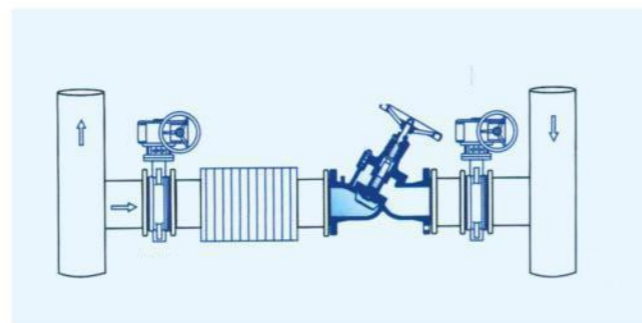

Unit: mm

Main external connection dimensions

DN	32	40	50	65	80	100	125	150	200	250	300	350
L	185	205	235	295	315	355	400	480	600	730	850	980
H	275	275	305	345	395	430	283	285	467	480	515	1035

Dynamic balancing electric regulating valve

Product overview

The dynamic balance electric regulating valve adopts a new design concept and is widely used in central air conditioning automation control and heating system automation control. In practical applications, when pipeline water pressure fluctuates, this product can dynamically balance system pressure changes, ensuring that the valve's flow characteristic curve during operation matches the ideal flow characteristic curve without design deviation. The unique design of the dynamic balance electric regulating valve ensures that its regulation is solely controlled by the control signal and is unaffected by system pressure fluctuations. At a fixed opening, the flow rate is always unique and constant, so the heat/cold delivered by the dynamic balance electric regulating valve is stable at any regulation position. It is particularly suitable for variable flow systems with significant load changes, featuring notable characteristics such as resistance to pressure interference, stable operation, high regulation accuracy, and energy efficiency.



Technical Parameters

PN (Pressure Rating)	PN16, PN25 optional
Flange Connection Standard	ISO 7005, JB/T 4700-200, and ANSI B16.5
Leakage Rate	0.02% of Kvs value
Permitted media	Water valve (2°C to 90°C) chilled water, cooling water, antifreeze water, refrigerant
Allowable working pressure	1.6 MPa, 2.5 MPa
Stroke	20mm (for DN65 and below), 40mm (for DN80 and above)
Valve body material	Cast iron
Valve core	Stainless steel
Valve stem	Stainless Steel
Sealing Surface	Polytetrafluoroethylene (PTFE)
Sealing Structure	V-Shaped Seal Ring + Stainless Steel Spring Self-Compensation

Product Features

High shut-off pressure differential of the valve, with very low leakage;

Valve body is made of cast steel material, surface treated for rust prevention, with an exquisite appearance;

Uses a linear stroke regulating actuator, providing accurate flow output as: equal percentage curve or linear curve (freely set via the DIP switch on the actuator);

The dynamic balancing section employs a bellows balancing design, enabling easy dynamic balance even under significant upstream pressure fluctuations;

Actuator control signal: 0(2)-10VDC, 0(4)-20mA (freely set via the DIP switch on the actuator); actuator valve position feedback signal: 0(2)-10VDC, 0(4)-20mA (freely set via the DIP switch on the actuator).

Technical Parameters

DN(mm)	Pipe Diameter(in)	PN	Kvs(m ³ /h)	Rated flow at 0.2 bar differential pressure (m ³ /h)	Maximum Media Temperature °C	Stroke(mm)	Drive torque (N)	Shut-off differential pressure (MPa)	Valve body + drive weight (kg)
25	1"	16/25	8	4	90	20	500N	≤0.30	21
32	1 1/4"	16/25	12.5	7	90	20	500N	≤0.30	23
40	1 1/2"	16/25	20	11	90	20	500N	≤ 0.30	25
50	2"	16/25	32	17	90	20	1000N	≤ 0.30	28
65	2 1/2"	16/25	50	28	90	40	1800N	≤ 0.30	35
80	3"	16/25	80	40	90	40	1800N	≤ 0.30	43
100	4"	16/25	125	63	90	40	3000N	≤ 0.30	63
125	2"	16/25	160	80	90	40	3000N	≤ 0.30	80
150	2"	16/25	200	100	90	40	3000N	≤0.30	95
200	8"	16/25	260	130	90	40	3000N	≤0.30	155

Electric Valve

Product Overview

The JQ-818 series on/off electric valve consists of a JQ-818 series valve actuator and a JQ-818 series brass valve. It is used to control the opening or closing of chilled or hot water air conditioning system pipelines to regulate room temperature. The actuator is driven by a unidirectional hysteresis synchronous motor, with the valve spring reset. The valve remains normally closed when inactive; when operation is required, the thermostat provides an opening signal, energizing the electric valve with AC power to open it, allowing chilled or hot water to enter the fan coil unit and provide cooling or heating for the room. When the room temperature reaches the thermostat setpoint, the thermostat cuts power to the electric valve, and the return spring closes the valve, thereby stopping water flow into the fan coil unit. Through valve closing and opening, room temperature is consistently maintained within the range set by the thermostat. The actuator and valve body of the JQ-818 series electric valve are connected via a threaded sleeve, allowing the actuator to be installed after the valve is in place, enabling flexible and convenient on-site assembly and wiring. The actuator's flat design permits installation close to the wall, occupying minimal space. The product is reliable, durable, operates with low noise, and can reliably function in high-temperature environments commonly found in concealed fan coil units.

Technical Parameters

	JQ818-15	JQ818-20	JQ818-25	JQ818-15S	JQ818-20S	JQ818-25S
Valve Size (Inch)	1/2"	3/4"	1"	1/2"	3/4"	1"
Flow Coefficient Kv	1.5	2.5	4.8	1.5	2.5	4.8
Shut-off Pressure Difference (MPa)	0.1	0.08	0.08	0.1	0.08	0.08
Valve Type	Two-way			Three-way		
Operating voltage	Standard: 220VAC, 50/60Hz; Optional: 24VAC 50/60Hz					
Valve body pressure rating	PN16 (1.6MPa)					
Power consumption	<7W					
Locked-rotor torque	≥95mNm					
Protection rating	IP55					
Valve body material	Cast brass					
Fluid temperature	1-95°C					
Suitable Medium	Refrigerant/Hot Water					
Ambient Temperature	5-60°C, 10%-95% RH non-condensing					
Pressure Rating (MPa)	2.5					

Product Overview

Automatic production line manufacturing; advanced surface treatment process; motor stall torque ≥95mNm/m; valve body made of high-grade forged brass; stainless steel (AISI302) valve stem; sealing material: fluor elastomer; actuator base: die-cast aluminum alloy; actuator cover: flame-retardant ABS.



Product Overview

The JQ-828 series electric valve is used to control the opening or closing of pipelines in central air conditioning systems and heating systems, achieving the purpose of regulating room temperature. The control valve is driven by a unidirectional hysteresis synchronous motor with a dual-spring reset. When not in operation, the valve remains normally closed. When activation is required, the thermostat provides an opening signal, causing the electric valve to connect to AC power and actuate, opening the valve to allow chilled water or hot water to enter the fan coil unit, providing cooling or heating for the room. When the room temperature reaches the thermostat's set value, the thermostat cuts power to the electric valve, and the reset spring closes the valve, thereby stopping the flow of water into the fan coil unit. Through the valve's closing and opening, the room temperature is consistently maintained within the range set by the thermostat.

The JQ-828 series electric valve can be optionally equipped with auxiliary switches for controlling other equipment; different connection forms and applicable voltages are available to meet various needs.

The JQ-828 series electric valve operates flexibly, is reliable and durable, has low working noise, and can withstand high-temperature environments commonly found in concealed fan coil units.

Technical Parameters

	JQ828-15	JQ828-20	JQ828-25	JQ828-15S	JQ828-20S	JQ828-25S
Valve Port Diameter (Inches)	1/2"	3/4"	1"	1/2"	3/4"	1"
Flow Coefficient Kv	2.2	3.0	6.8	2.2	3.0	6.8
Closing differential pressure (MPa)	0.20	0.18	0.15	0.20	0.18	0.15
Valve type	Two-way			Three-way		
Operating voltage	Standard: 220VAC, 50/60Hz; Optional: 24VAC 50/60Hz					
Valve body pressure resistance	PN16(1.6MPa)					
Power consumption	<7W					
Protection rating	IP55					
Valve body material	Cast brass					
Liquid Temperature	0-95°C					
Suitable Medium	Chilled/Hot Water					
Ambient Temperature	5-60°C, 10%-95% RH non-condensing					
Pressure Rating (MPa)	2.5					

Product Overview

Fully independently developed and produced; motor locked-rotor torque ≥95mNm/m, all-metal driver structure, stable; double-spring balance design; metal buckle for easy valve body installation; sealing material, fluororubber.



Electric valve

Product Overview

The JQ-858 series electric ball valve uses a permanent magnet reversible synchronous reduction motor to drive a low-torque standard ball valve. The motor remains powered only for the dozen seconds during the valve opening or closing process, and automatically cuts off once the valve reaches its open or closed position.



Technical Specifications

	JQ858-15	JQ858-20	JQ858-25	JQ858-15S	JQ858-20S	JQ858-25S
Valve Port Size (Inches)	1/2"	3/4"	1"	1/2"	3/4"	1"
Valve Type	Two-way			Three-way		
Operating voltage	220V, 50/60Hz; 24V 50/60Hz					
Switching time	15S (50Hz)/12s (60Hz)					
Ambient temperature	65°C max					
Valve body pressure resistance	PN16 (1.6MPa)					
Relative humidity	95% max					
Power consumption	5VA (only when valve position is changed)					
Protection class	IP55					
Valve body material	Cast brass					
Liquid temperature	0-95°C					
Sphere core material	Brass chrome-plated, spring clamp: stainless steel					

Product Features

Precision-forged from high-grade brass, ensuring dense and tight valve components;

Straight-through water flow never clogs;
High flow capacity, over 3 times higher than traditional valves;

Kvs=21m³/h (3/4") suitable for any fan coil unit specification;

Valve closes tightly, absolutely no internal leakage;

Driver cuts power automatically after valve fully closes/opens, long service life;

Sealed structure resists moisture ingress, ensuring reliable motor operation;

Can be installed either vertically or horizontally;

Extremely low failure rate.

Technical Parameters

Valve model	Valve model	DN(m)	Rp(inch)	KVS(m ³ /h)	Actuator						
					Control Signal	Full Stroke Time	Nominal angle/Maximum angle	90° angle operating time	Torque value	Spring return function	Connection cable
2-way	3-way				3-Position AC 24V	150s	90°/95° ± 2'	90s	5Nm	None	0.9m
					0-10V AC 24V	150s	90°/95° ± 2'	150s	10Nm	None	0.9m
VA61.20-2	VA61.20-3	DN20	Rp3/4	4	1400	350					
VA61.20-2	VA61.20-3	DN20	Rp3/4	6.3	1400	350					
VA61.20-2		DN25	Rp3/4	10	1400	350					
VA61.25-2		DN25	Rp1	6.3	1400	350					
VA61.25-2	VA61.25-3	DN25	Rp1	10	1400	350					
VA61.25-2		DN25	Rp1	16	1400	350					
VA61.32-2		DN32	Rp1 1/4	10			1000				350
VA61.32-2	VA61.32-3	DN32	Rp1 1/4	16			1000				240
VA61.32-2		DN32	Rp1 1/4	25			1000				240
VA61.40-2		DN40	Rp1 1/2	16			800				350
VA61.40-2	VA61.40-3	DN40	Rp1 1/2	25			800				240
VA61.40-2		DN40	Rp1 1/2	40			800				240
VA61.50-2		DN50	Rp2	25			600				350
VA61.50-2		DN50	Rp2	40			600				240
VA61.50-2	VA61.50-3	DN50	Rp2	63			600				240

Product Applications

The JQ series electric ball valves are suitable for HVAC systems, serving as control and safety shut-off valves, and are applicable to closed systems.

Product Features

Suitable for DN20 to DN50 two/three-way threaded ball valves;

Hysteresis clutch motor; locked rotor will not burn out the motor;

Manual adjustment function;

Analog adjustment (DC0-10V) or three-position controlled ball valve suitable for valve

VA61.. series ball valve angular stroke actuator;

Operating voltage: AC24V;

Position signal: three-position floating point, with a 0.9-meter long wire;

Ambient temperature: -32 to 55°C.

Actuator/Control Valve

Product Overview

VA-3100 Floating Point Actuator

The floating point actuator, combined with our company's proportional-integral LCD thermostat, activates the corresponding open valve relay when the indoor temperature exceeds the set temperature (cooling mode) or falls below the set temperature (heating mode) by 1°C, operating in a pattern of 45 seconds on and 15 seconds off. When the indoor temperature is below the set temperature (cooling mode) or above the set temperature (heating mode) by 1°C, the corresponding close valve relay activates, following the same 45-second on, 15-second off cycle. In all other states, all relays remain inactive, and the valve maintains its current position.

VA-3200 Analog Actuator

Automatically measures valve stem travel for better control precision. The mechanical tightening function after valve closure: after reaching the closed position, the actuator continues to operate for 7 seconds (software function) to ensure the valve is fully shut tight and prevent internal leakage; uses a linear stroke regulating actuator, with accurate flow output as: equal percentage curve or equal linear curve (freely set via DIP switch on the actuator).

Technical Parameters

Standard Valve Models	JQ858-15	JQ858-20	JQ858-25	JQ858-15S
Actual Output Force (N)	800N	1000N	800N	1000N
Operating Type	Floating-point type			Analog type
Power supply	Standard 24VAC ±15% optional 220VAC		24VAC ±15%	
Power consumption	5.5VA		7.5VA	
Weight (kg)	1		1.1	
Input/feedback signal	Float (no feedback signal)		0-10V or 2-10V	
Input 5GDS			0-20mA or 4-20mA	
Voltage input impedance			>100k	
Current input impedance			<0.50k	
Current output load requirement			>1k	
Current output load requirement			<0.51k	
Upper and lower limit deadband range			≤3.5%	
Sensitivity			±0.2V	
Valve Connection Size	1/4-28UNF-2B			
Maximum Stroke (mm)	25			
Operating Speed (mm/s)	0.3			
Height (mm)	205			
Operating ambient temperature	1°C ~ 60°C, 10% to 95% RH, non-condensing			
Storage temperature	20°C ~ 85°C			
Applicable valve body range	Brass threaded valves and cast steel flange valves			

Product Features

Die-cast aluminum bracket and PC engineering plastic housing are used;

Low power consumption, minimal noise, high output torque;

Flexibly combined with the valve body to meet different pressure differential requirements;

Hysteresis clutch motor, featuring hysteresis clutch protection, capable of generating stable torque during pauses to hold the valve at any position;

Forward/reverse rotation control: Wiring can be flexibly configured for forward or reverse rotation as needed to match different valve bodies.



Product Overview

The VB-3X00 series threaded brass valves, when paired with electronic drive control devices, can regulate the flow of steam or cold/hot water.

Brass threaded valves are widely used for fluid control in systems such as central air conditioning, heating, water treatment, and industrial processing.

Technical Parameters

Standard Valve Models	VB-3200-25	VB-3200-32	VB-3200-40	VB-3200-50	VB-3200-65	VB-3300-25	VB-3300-32	VB-3300-40	VB-3300-50	VB-3300-65
Dimensions (mm)	25	32	40	50	65	25	32	40	50	65
Type	Two-way					Three-way				
Flow coefficient (Kv)	8	16	25	40	63	8	16	25	40	63
Standard valve maximum VA-31xx actuator	1	0.75	0.5	0.3	0.2	1	0.75	0.5	0.3	0.2
Pressure difference (MPa) VA-32xx actuator	1.4	1.1	0.8	0.5	0.35	1.4	1.1	0.8	0.5	0.35
Stem travel (mm)	15	19	19	22	22	15	19	19	22	22
Connection Type	Threaded									
Material	Valve Body/Cover: Cast Brass					Stem: 1cr18Ni9 Stainless Steel				
	Valve Plate/Valve Cover: Cast Brass + Fluororubber Sealing Gasket					Stem Seal: PTFE Packing and O-ring Fluororubber Seal Combination				
Pressure Rating	95°C/16MPa									
Working Medium	Water									
Fluid temperature	2-94°C									
Fluid characteristics	Equal percentage									
Leakage	Not greater than 0.05% of Kv value									
Closing direction	Downward movement of the stem is the valve closing direction									
Connection thread	GB/T7306.1 national standard cylindrical internal thread									

Product features

The valve body and actuator can be flexibly combined to adapt to different pressure differential needs;

High-grade die-cast brass, 100% tested with 2.5Mpa water pressure; valve body structures include two-way, three-way mixing, and three-way diverting

Equal percentage flow characteristic; Threaded connection, its construction complies with IEC international standards;

Standard valves use forged brass valve plates, PTFE packing paired with stainless steel stem seals, featuring low noise and low leakage;

Valve stem travel is available in 15mm and 22mm.

Electric Control Valve



Product Overview

VA-7100 Floating Point Actuator

The floating point actuator, combined with our company's proportional-integral LCD thermostat, activates the corresponding open valve relay when the indoor temperature exceeds the set temperature (cooling mode) or falls below the set temperature (heating mode) by 1°C, operating in a pattern of 45 seconds on and 15 seconds off. When the indoor temperature is below the set temperature (cooling mode) or above the set temperature (heating mode) by 1°C, the corresponding close valve relay activates, following the same 45-second on, 15-second off cycle. In all other conditions, all relays remain inactive, and the valve maintains its current state.

VA-7200 Analog Actuator

The stroke self-test function automatically measures the valve body stroke for better control accuracy; The post-closure tightening function allows the actuator to continue running for 7 seconds (software feature) after the valve reaches the closed position, ensuring a complete seal to prevent internal leakage;

Linear stroke modulating actuator, with accurate flow output as: equal percentage curve or linear curve (freely set via the actuator's DIP switch).

Technical Parameters

Standard Valve Models	VA-7100-2500	VA-7100-4000	VA-7200-2500	VA-7200-4000
Actual Output Force (N)	2500N	4000N	2500N	4000N
Job Type	Floating Point		Analog Type	
Power Supply	Standard 24VAC ±15% optional 220VAC		24VAC ±15%	
Power Consumption	10VA		12VA	
Weight (kg)	3.65		3.75	
Input/Feedback Signal	Floating Point (No Feedback Signal)		0-10V or 2-10V	
Input/Output Signal			0-20mA or 4-20mA	
Voltage input impedance			>100k	
Current input impedance			<0.50k	
Current output load requirement			>1k	
Current output load requirement			<0.51k	
Upper and lower limit deadband range			≤3.5%	
Sensitivity			±0.2V	
Valve connection size	Clamp snap connection			
Maximum stroke (mm)	60			
Operating speed (mm/s)	0.23(50Hz)			
Height (mm)	345			
Operating Environment Temperature	1°C-60°C, 10%-95% RH non-condensing			
Storage Temperature	20°C - 85°C			
Applicable Valve Body Range	Cast Steel Flange Valve			

Electric Control Valve

VA-7200 Analog Drive

The actuator uses die-cast aluminum brackets and an aluminum alloy housing;

The valve body and actuator can be flexibly combined to adapt to different pressure differential requirements;

Low power consumption, low noise, and high output torque;

Forward/reverse control: Wiring can be flexibly configured for forward or reverse rotation as needed to match different

Valve body;

The actuator uses a reversible motor with overload protection. It can generate stable torque when stopped,

allowing the valve to remain stationary at any position;

The valve body is connected by spring clips for easy installation and removal.

Application

The VB-7X00 series electric regulating valve body can be used with the A-7×00 series actuator. Through precise regulation and control of the valve body, it achieves adjustment of medium flow in system pipelines, thereby meeting control objectives such as constant temperature, pressure, and humidity in the system. It is widely used in air conditioning, heating, and other building automation systems.



Product Features

Flexible combination of valve body and actuator to adapt to different pressure differential needs;

Valve body connection method is flange, with construction conforming to IEC international standards;

Valve body structures include two-way, three-way mixing, and three-way diverting;

Equal percentage flow characteristic;

NP16 flange connection;

Standard valves use cast bronze discs and PTFE packing with stainless steel compensation

springs to form seals, featuring low noise and minimal leakage;

The valve stem travel ranges from 25mm to 43mm.

Technical Specifications

Standard Valve Models	VB-7200-65	VB-7200-80	VB-7200-100	VB-7200-125	VB-7200-150	VB-7300-65	VB-7300-80	VB-7300-100	VB-7300-125	VB-7300-150
Dimensions (mm)	65	80	100	125	150	65	80	100	125	150
Flow coefficient (Kv)	49	78	124	200	300	49	78	124	200	315
Standard valve maximum pressure differential (MPa)	0.8	0.6	0.4	0.3	0.2	0.8	0.6	0.4	0.3	0.2
Stem travel (mm)	25	30	43	43	43	25	30	43	43	43
Type	Two-way					Three-way				
Material	Connection method: Standard Flange Valve Body/Bonnet: HT250/Q235A Valve Stem: 1Cr18Ni9(AISI302)09 Stainless Steel Runpan: Cast Bronze Stem Seal: PTFE Packing + Stainless Steel Compensation Spring Shaft Seal Sleeve: Brass									
Pressure Rating	1.6 MPa									
Working medium	Water									
Fluid temperature	2-95°C									
Fluid characteristics	Equal percentage									
Connection type	NP16 flange									
Leakage	Not exceeding 0.05% of the Kv value									
Closing direction	Stem downward movement is the valve closing direction									

EDRV Series Dynamic Balancing Electric Control Valve

Product Overview

The EDRV Dynamic Balancing Electric Control Valve is a new-generation product that differs from traditional electric control valves, integrating dynamic balancing and electric regulation. As shown in the figure below, in flow systems with significant system fluctuations, when system pressure changes, the differential pressure P1-P3 across the two stages of the EDRV valve also changes accordingly

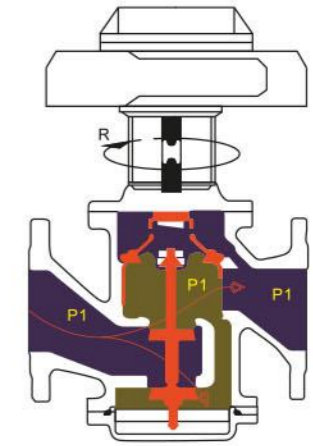

(1) When the inlet pressure P1 increases, the increase in P1-P2 causes the electric valve spool to move upward, reducing the opening between P1 and P2 and lowering the spool pressure P2; when the inlet pressure P1 decreases, the opening between P1-P2 increases and the spool pressure P2 rises. Thus, regardless of changes in system pressure, the pressure difference between the P2 and P3 ports remains constant due to the regulating action of the electric valve spool. Consequently, this electric valve has strong anti-interference capability and features dynamic balancing functionality;

(2) When the electric actuator receives a control signal causing the valve stem to rotate in the R direction, the opening of the P2 and P3 keys also changes. Since the pressure difference P2-P3 between the P2 and P3 keys remains constant regardless of changes in the system pressure difference P1-P3, the water flow rate delivered corresponds to any opening position is constant. Moreover, the actual flow characteristic curve of this electric regulating valve matches its inherent flow characteristic curve without deviation, thus giving this electric regulating valve better regulation performance than traditional electric regulating valves.

Dynamic Balance Electric Regulating Valve Curve

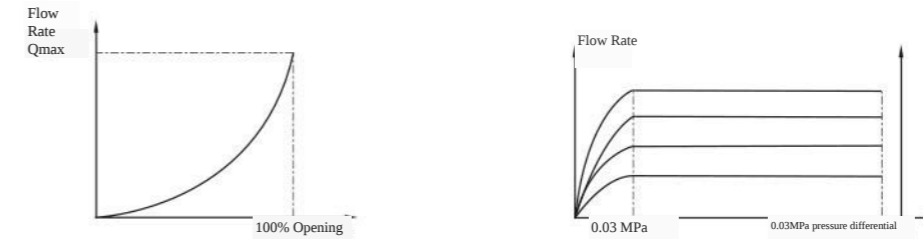

Material

Valve body	Valve sleeve	Valve core	Diaphragm	Seal	Electric Actuator Housing
Ductile Iron	Stainless Steel	Brass	EPDM	PTFE	Aluminum Alloy

Technical Parameters of Electric Actuators

Product Number	Operating Voltage	Torque	Power	Input Signal	Output signal	Ambient temperature	Water resistance	Weight
9012465	230VAC24V AC	50N.M	100W	0-10VAC4-20mA1-5VDC	0-10VDC4-20mA	10-60°C	P65	2.8kg
9012466	230VAC24V AC	100N.M	23W	0-10VAC4-20mA1-5VDC	0-10VDC4-20mA	-10-60°C	P65	3.9kg

EDRV Series Dynamic Balancing Electric Control Valve

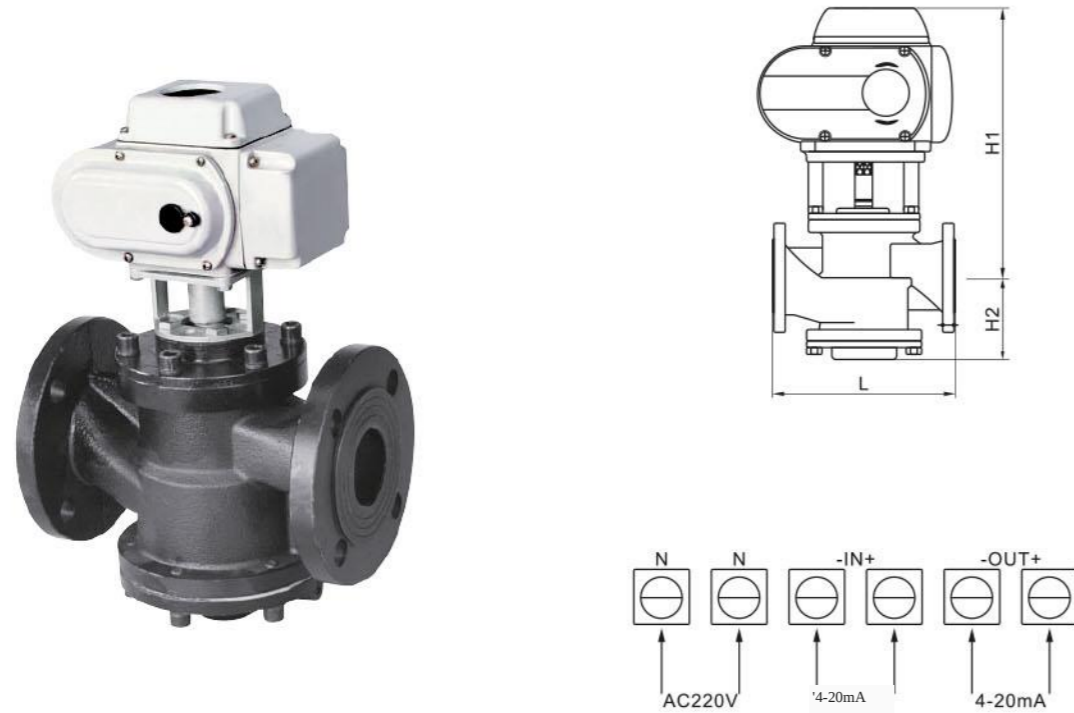

Technical Parameters of Dynamic Balancing Electric Control Valve

Product Number	Valve Type	Model	Specifications	Differential Pressure Range (KPa)	Flow Range (m ³ /h)	Operating Pressure	Flow Error	Flow Temperature
9099508	Two-way	EDRV1	DN25	30-300	0.2-2.9	PN16	5%	0-100°C
9099510		EDRV2	DN32	30-300	0.5-4.7			
9099512		EDRV3	DN40	30-300	1-7.7			
9099550		EDRV4	DN50	30-300	2-12.1			
9099551		EDRV5	DN65	30-300	3-20.4			
9099552		EDRV6	DN80	30-300	5-30.8			
9099553		EDRV7	DN100	30-300	10-45.3			
9099554		EDRV8	DN125	30-300	15-70.7			
9099555		EDRV9	DN150	30-300	20-101.8			
9099556		EDRV10	DN150	40-400	30-110			

Dynamic balance electric control valve dimensional parameters

Product number	Valve type	Model	Specifications	Dimensions (mm)		
				Length (L)	Height below centerline (H2)	Height above centerline (H1)
9099508	Two-way valve	EDRV1	DN25	160	70	265
9099510		EDRV2	DN32	180	110	275
9099512		EDRV3	DN40	200	110	285
9099550		EDRV4	DN50	230	120	290
9099551		EDRV5	DN65	290	124	339
9099552		EDRV6	DN80	310	150	348
9099553		EDRV7	DN100	350	158	357
9099554		EDRV8	DN125	400	193	379
9099555		EDRV9	DN150	480	193	379
9099556		EDRV10	DN150	480	193	379

EVR Series Dynamic Balancing Valve

Dynamic Balancing Valve Technical Specifications

Basic Specifications: DN50-DN800

Working Pressure: 16Bar/25Bar

Flow Error: ±5%

Operating Temperature: 0 ~ 120°C

Valve body: Ductile iron (QT400-18)

Valve core: Stainless steel (304-2B)

Spring: Stainless steel (1Cr18Ni9)

O-ring: Nitrile rubber (N220SH)

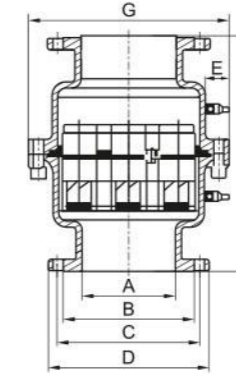

Dimensions and weight

Product number	Caliber	B(mm)	C(mm)	D(mm)	E(mm)	F(mm)	G (mm)	Weight (kg)
ERV95 50	DN50	99	125	165	38	239	218	16
ERV95 51	DN65	188	145	185	38	239	218	19
ERV9552	DN80	132	160	200	38	239	218	22
ERV9553	DN100	156	190	235	38	365	270	38
ERV95 54	DN125	184	220	270	38	365	295	46
ERV95 55	DN150	211	250	300	38	410	354	66
ERV95 56	DN200	274	310	360	38	430	484	96
ERV95 57	DN250	330	370	425	38	456	488	128
ERV95 58	DN300	389	430	485	38	466	565	187
ERV95 59	DN350	448	490	555	38	479	700	249
ERV95 60	DN400	503	550	620	38	504	790	356
ERV95 61	DN450	548	640	670	38	517	800	418
ERV95 62	DN500	609	660	730	38	520	880	518
ERV95 63	DN600	720	770	845	38	554	1050	718
ERV95 64	DN800	928	990	1085	38	557	1260	865

Differential pressure and flow range

DN (mm)	Differential pressure range (KPa)		Flow range (m ³ /h)	Maximum number of valve cores (pcs)	DN(mm)	Differential pressure range (KPa)		Flow range (m ³ /h)	Maximum number of valve cores (pcs)
	15-150	3.2-390				15-150	3.2-390		
50	22-210	4.0-36	1	13	250	33-330	5.0-598	8.0-975	20
	33-330	5.0-46				90-900	8.0-1500		
	90-900	8.0-75				15-150	3.2-600		
	15-150	3.2-30				22-210	4.0-720		
65	22-210	4.0-36	1	23	300	33-330	5.0-1058	8.0-1725	30
	33-330	5.0-46				90-900	8.0-1500		
	90-900	8.0-75				15-150	3.2-690		
	15-150	3.2-30				22-210	4.0-828		
80	22-210	4.0-36	1	23	350	33-330	5.0-1058	8.0-1725	37
	33-330	5.0-46				90-900	8.0-1500		
	90-900	8.0-75				15-150	3.2-900		
	15-150	3.2-30				22-210	4.0-828		
100	22-210	4.0-72	2	30	400	33-330	5.0-1380	8.0-2250	47
	33-330	5.0-92				90-900	8.0-2250		
	90-900	8.0-150				15-150	3.2-1110		
	15-150	3.2-60				22-210	4.0-1332		
125	22-210	4.0-108	3	37	450	33-330	5.0-1702	8.0-2775	47
	33-330	5.0-138				90-900	8.0-2775		
	90-900	8.0-225				15-150	3.2-1410		
	15-150	3.2-150				22-210	4.0-1692		
150	22-210	4.0-150	5	47	500	33-330	5.0-2162	8.0-3525	64
	33-330	5.0-230				90-900	8.0-3525		
	90-900	8.0-375				15-150	3.2-1920		
	15-150	3.2-240				22-210	4.0-2304		
200	22-210	4.0-288	8	64	600	33-330	5.0-2944	8.0-4800	95
	33-330	5.0-368				90-900	8.0-4800		
	90-900	8.0-600				15-150	3.2-2850		
	15-150	3.2-240				22-210	4.0-3420		
800	33-330	5.0-1370	8	95	800	33-330	5.0-1370	8.0-7125	95
	90-900	8.0-600				90-900	8.0-7125		
	15-150	3.2-2850				22-210	4.0-3420		

Fire-Resilient Seat Seal Gate Valve

Product Overview

Signal gate valves are commonly used in automatic sprinkler fire protection pipeline systems to monitor water supply lines, allowing remote indication of valve opening. Rising stem gate valves and gate valves with opening indicators are also frequently used in fire protection systems. If the valve is installed at a higher position, a rising stem gate valve is typically used to clearly indicate the valve opening; if the installation position is lower, a gate valve with an opening indicator is required.

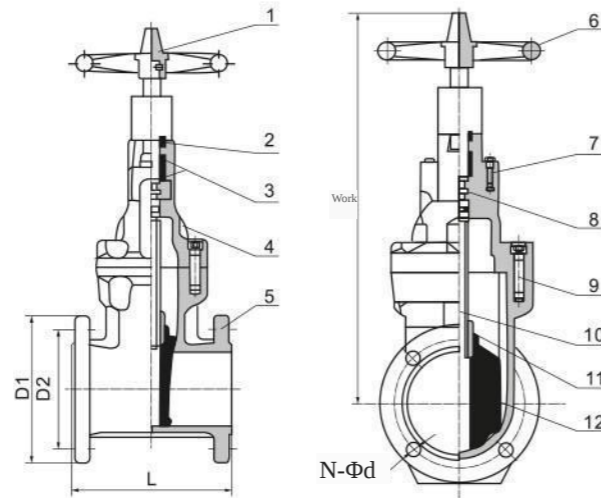

Main part materials

NO.	Part name	Material
1	Transmission cap	GG25
2	Dust cover	NBR
3	O-ring	NBR
4	Valve cover	GG25
5	Valve body	GG25
6	Handwheel	GG25
7	Shaft cover	GG25
8	Thrust bearing	BRINZE
9	Bolt	SUS410
10	Valve stem	SUS410
11	Copper nut	BRONZE
12	Valve disc	GG25 coated with EPDM or NBR

Technical Parameters

DN	DN50-400mm
Nominal Pressure	1.0/1.6/25 MPa
Operating Temperature	-10°C – 80°C
Sealing Pressure	1.1
Valve body pressure resistance	1.5
Applicable medium	Water, oil, gas

Main external connection dimensions

Unit: mm

Product name	DN	D1		D-Fd	L	H
		1.0MPa	1.6MPa			
Rising Stem, Non-Rising Stem, Underground Resilient Seat Gate Valve	50	135	125	4-19	178	340
	65	185	145	4-19	190	370
	80	200	160	8-19	203	410
	100	220	180	8-19	229	450
	125	250	210	8-19	254	480
	150	285	240	8-23	267	550
	200	340	295	8-23 12-23	292	630
	250	405	350 355	12-23 12-28	330	750
	300	460	400 410	12-23 12-28	356	820
	350	520	460 470	16-23 16-28	381	980
400	580	515 525	16-28 16-31	406	1010	

Fire Special Resilient Seat Sealed Gate Valve

Product Overview

In addition to the advantages of resilient seat gate valves, rising stem resilient seat gate valves are often used in fire protection and industrial systems, typically installed at higher positions above the ground, as they can visually indicate the valve opening.

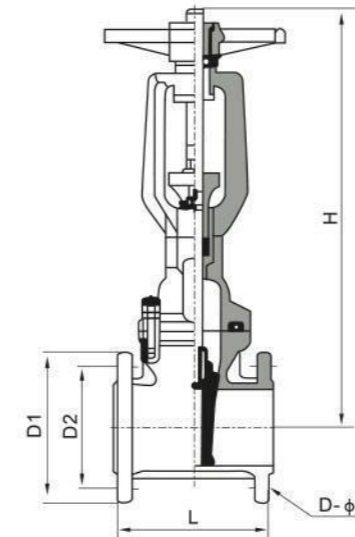

Technical Parameters

DN	DN50-400mm
Nominal Pressure	1.0/1.6/25 MPa
Operating Temperature	-10°C – 80°C
Sealing Pressure	2.0
Valve Body Pressure Rating	4.0
Applicable Medium	Water, Oil, Gas

Main external connection dimensions

Unit: mm

Product name	DN	D1		D2		D-φd	L	Fully open	Fully open
		1.0 MPa	1.6 MPa	1.0 MPa	1.6 MPa				
Rising Stem, Non-Rising Stem, Underground Resilient Seated Gate Valve	50	135	125	135	125	4-19	178	322	374
	65	185	145	185	145	4-19	190	332	398
	80	200	160	200	160	8-19	203	350	429
	100	220	180	220	180	8-19	229	420	524
	125	250	210	250	210	8-19	254	581	721
	150	285	240	285	240	8-23	267	581	736
	200	340	295	340	295	8-23 12-23	292	736	942
	250	405	350 355	405	350 355	12-23 12-28	750	882	1013
	300	460	400 410	460	410	12-23 12-28	820	1009	1117
	350	520	460 470	520	470	16-23 16-28	980	1300	1655
400	580	515 525	580	525	16-28 16-31	1010	1380	1805	

Fire-specific Butterfly Valve

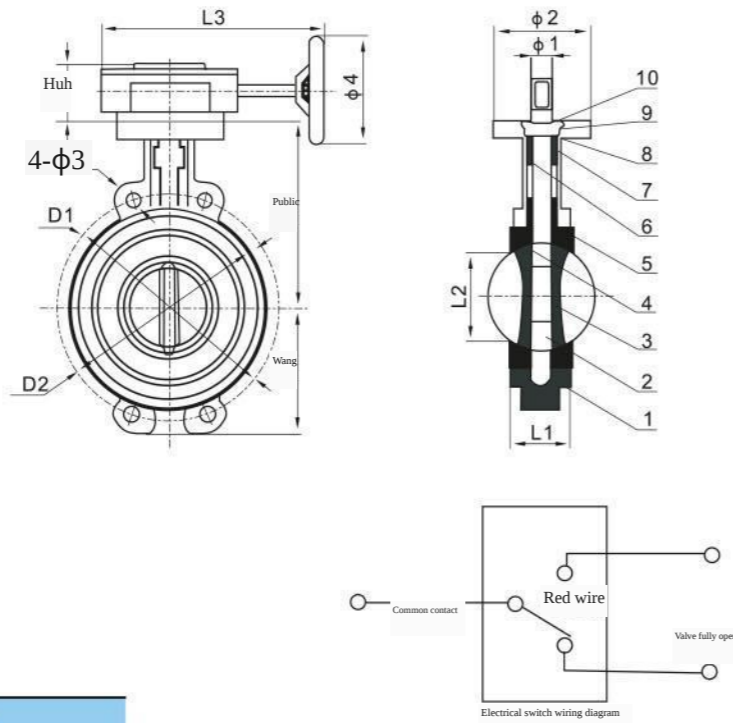

Main component materials

No.	Part name	Material
1	Valve body	Iron ball, cast steel
2	Valve shaft	SUS410/SUS316
3	Butterfly plate	Ductile iron plated, stainless steel
4	Valve seat	EPDM, PTFE
5	Valve seat back	Phenolic resin
6	Bushing	Bronze, PTFE
7	Sealing ring	NBR, EPDM
8	Gasket	SUS316/Brass
9	Split ring	SUS316/Brass
10	Retaining ring	Spring steel

Technical parameters

DN	DN50-400mm
Nominal pressure	1.0/1.6/2.5 MPa
Operating temperature	-10°C - 80°C
Sealing Pressure	1.1
Valve Body Pressure Resistance	1.5
Applicable Medium	Water, Oil, Gas

Main External Connection Dimensions

Unit: mm

Product Name	DN	H1	H2	H3	D1	D2	L1	L2	L3	Φ1	Φ2	Φ4
ZSXF Signal Butterfly Valve D371X Worm Gear Butterfly Valve	50	70	130	68	120	95	43	32	245	12.6	70	152
	65	76	143	68	136	109	46	47	245	12.6	70	152
	80	86	155	68	160	124	46	65	245	12.6	70	152
	100	104	170	68	182	153	52	91	245	15.8	90	152
	125	118	190	68	215	179	56	112	245	19	90	152
	150	132	210	68	238	206	56	146	245	19	90	152
	200	167	243	85	295	264	60	194	400	22.1	115	300
	250	198	282	85	357	316	68	242	400	28.5	115	300
	300	239	310	52	407	373	68	292	400	31.7	140	305
	350	267	368	82	467	436	78	325	400	31.7	140	305
400	309	400	121	515	488	102	380	431	33.15	197	290	

Groove Type Gate Valve

Product Overview

The grooved (clamp) connection gate valve is a new series of connection valves designed and manufactured based on advanced similar products from the United States and Germany. It offers advantages such as quick, simple, safe, and reliable installation, unrestricted by site conditions, easy maintenance of pipelines and valves, vibration and noise isolation, and the ability to compensate for misalignment within a certain angle range and address thermal expansion and contraction caused by temperature differences.

Widely used in water supply and drainage, fire protection, air conditioning, gas, petroleum, chemical, water treatment, municipal, shipbuilding, and other pipeline engineering for fluid control.



Z85X



ZK85X

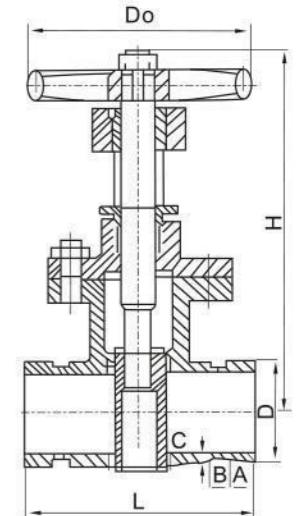

Main Component Materials

Product Type	Material			
	Valve body	Valve plate	Valve shaft	Sealing surface
Cast iron	HT200	Ductile iron, carbon steel, coated or stainless steel	Chromium stainless steel	Copper or stainless steel
Ductile iron	QT450			Steel
Copper	Copper	Ductile iron, carbon steel, coated or stainless steel	Stainless Steel	Copper or stainless steel
Carbon steel	WCB			NBR rubber, nitrile rubber, NBR, ethylene-propylene, EPDM, fluororubber, PTFE, polytetrafluoroethylene plastic, F46
Stainless steel	1Cr18Ni9Ti (304)			

Main External Connection Dimensions

Unit: mm

DN	50	65	80	100	125	150	200	250	300	350	400	450	500	600
D	57	60	76	89	108	114	133	140	158	165	219	273	325	377
A	14.5	14.5	14.5	16	16	16	19	19	19	25	25	25	25	25
B	9.5	9.5	9.5	9.5	9.5	9.5	13	13	13	13	13	13	13	13
C	2.2	2.2	2.2	2.2	2.2	2.2	2.5	2.5	3.3	3.3	5.5	5.5	5.5	5.5
Z81XZ8 5XZK85 X	L	145	160	170	180	200	240	275	325	355				
	H	325	380	425	455		500	620	750	880				
	D	180	180	200	200		240	320	320	400				

Grooved Butterfly Valve

Product Overview

The grooved (clamp) connection butterfly valve is a new series of connection valves designed and manufactured based on similar advanced products from the United States and Germany. It features quick, simple, and safe installation, high reliability, no restrictions on installation sites, ease of maintenance for pipelines and valves, vibration and noise isolation, and the ability to compensate for misalignment within a certain angle range, as well as advantages like addressing thermal expansion and contraction due to temperature differences.

Widely used in water supply and drainage, firefighting, air conditioning, gas, petroleum, chemical, water treatment, municipal, shipbuilding, and other pipeline engineering for fluid control.

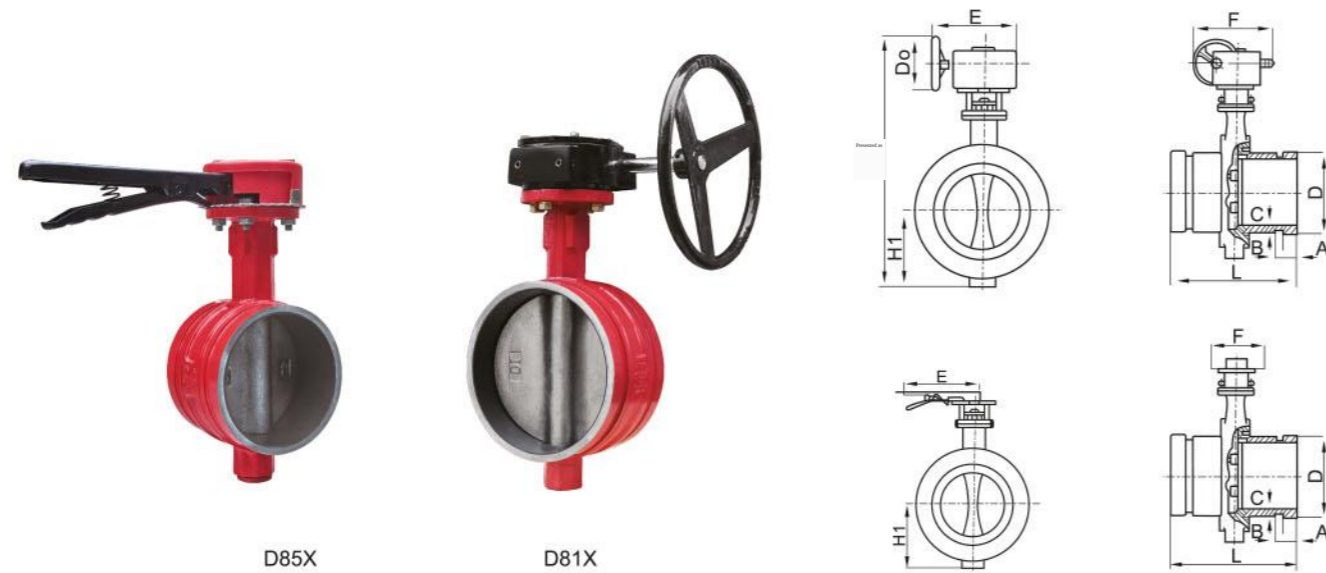

Main Component Materials

Product Type	Material			
	Valve Body	Valve Plate	Valve Shaft	Sealing Surface
Cast iron	HT200	Ductile iron, carbon steel, coated or stainless steel	Chrome stainless steel	Copper or stainless steel
Ductile iron	QT450			Rubber NBR, nitrile rubber NBR, EPDM, fluororubber PTFE, polytetrafluoroethylene F46
Copper	Copper	Copper or stainless steel		Steel
Carbon steel	WCB	Ductile iron, carbon steel, coated or stainless steel		Copper or stainless steel
Stainless steel	1Cr18Ni9Ti (304)		Stainless steel	

Main external connection dimensions D41/341X-10/16

Unit: mm

DN	50	65	80	100	125	150	200	250	300	350	400	450	500	600					
D	57	60	76	89	108	114	133	140	159	165	168	219	273	325	377	426	480	530	630
A	14.5	14.5	14.5	16	16	16	19	19	19	25	25	25	25	25	25	25	25	25	25
B	9.5	9.5	9.5	9.5	9.5	9.5	13	13	13	13	13	13	13	13	13	13	13	13	13
C	2.2	2.2	2.2	2.2	2.2	2.2	2.5	2.5	3.3	3.3	5.5	5.5	5.5	5.5	5.5	5.5	5.5	5.5	5.5
D81XD 85X	L	88	90	96	115		132	147	159	165	165	170	180	190	210				
	H1	60	75	80	94		125	150	220	250	265	300	330	350	410				
	H0	220	245	270	300		350	400	600	740	765	875	940	995	1130				
	E	245	245	245	245		245	260	260	330	330	425	425	425	425				
	F	65	65	65	65		65	90	125	180	190	210	210	210	210				
	D0	120	120	120	120		140	140	140	240	280	320	320	350	350				

Fire Flow Switch



Technical Specifications

Measurement range: Water: 3-300 cm/s; Gas: 200-3000 cm/s; Oil: 3-300 cm/s
 Switch accuracy: $\pm 1 \pm 10$ cm/s
 Warm-up time: 3 minutes after power-on
 Operating pressure: 100 Bar
 Medium temperature: $-20^{\circ}\text{C} - 80^{\circ}\text{C}$
 过程连接: G1/2(标准), (其他可选)
 输出信号: 继电器(SPDT)
 Contact capacity: 30VDC/10A, 110VAC/10A, 220VAC/10A
 开关功能: 1. 设定值; 2. 报警回差; 3. 报警方式; 4. 报警稳定时间; 5. Alarm delay; 6. Adjustable damping
 Power supply: 18-32VDC
 Sensor length: 15mm (standard), other lengths optional
 Display: LCD shows working status and progress bar, with one LED alarm light
 Current consumption: <60mA
 Setting method: Button type, one-key setting
 Response time: 0.5s, damping adjustable from 1-10s
 Maximum media temperature change rate: 300k/min
 Electrical protection: Reverse/overload/short-circuit
 Protection rating: IP67
 Electrical connection: M20*1.5 explosion-proof connection
 Material: Probe: ANSI316L
 Body: Die-cast aluminum
 Explosion-proof: Ex d iIC T6 G6 (option)

Fire pressure switch



Product introduction:

消防压力开关是将水压的压力变化转化为电信号输出的消防可控开关。是各种自动喷淋系统的重要组成部分，常与湿报警阀、预作用报警阀、预作用报警系统、等，用于传输报警信号；当与火灾报警控制箱联动时，可启动消防泵。消防压力开关安装在湿报警阀报警管线的报警侧或预作用系统的网络侧。

Working Principle:

When water or air pressure reaches the specified value, the micro-switch contacts in the fire pressure switch activate, outputting an electrical signal to the fire control room.

Features:

消防压力开关为长方形壳体,外形漂亮美观.防水防尘,动作灵敏可靠,产品使用寿命长.用户可根据实际条件调整报警压力值.

Troubleshooting:

If the pressure switch alarms but the water motor alarm does not, it may be a fault in the switch or sensor drive, or a short circuit in the wiring (from the sensor drive section to the pressure switch). It could also be a water motor alarm failure; specifically, check whether the pump starts. If it does start, it is definitely a water motor alarm failure. If the pump does not start, then inspect the pressure switch wiring and drive section.

旋流防止器

旋流防止器概述

旋流防止器是一种用于防止水箱(池)在输送液体时产生旋流和防止空气进入管道的特殊管件。其作用是安装在水箱(池)水泵吸水管端口上,用来消除水箱(池)内的旋流,以确保水泵能一直全力启动并正常工作,避免空气进入水泵产生气蚀现象,能使水箱(池)里输送液体的液面降到较低液位,以确保达到最大的流量输送。

适用于化工、能源、水工程等领域,特别是在消防取水(箱)中使用,能保证有效容积被全部利用,提高消防水池有效利用率,减少死水区,实现节水要求。救援时,消防用水能得到最大限度的使用。

旋流防止器技术特点

1. 旋流防止器最低淹没深度可至100mm而不产生旋流,大大提高了水池的有效利用率。
2. 有效消除抽吸水过程中水箱(池)产生的旋流。
3. 防止因旋流夹着空气进入水泵,实现水泵高效能输水,避免水泵产生气蚀现象而被损坏
4. 旋流防止器的结构简便而结实,实现经济型安装、免维护。

国家规定:GB50974-2014《消防给水及消火栓系统技术规范》中第5.1.12条规定:

当消防水泵从消防水箱吸水时,因消防水箱设置吸水井困难,为减少吸水管的保护高度要求吸水管上设置旋流防止器,以提高消防水箱的储水有效量。第5.1.13条规定:消防水泵吸水口的淹没深度应满足消防水泵在最低水位运行安全的要求,吸水管喇叭口在消防水池最低有效水位下的淹没深度应根据吸水管喇叭口的水流速度和水力条件确定,但不应小于600mm,当采用旋流防止器时,淹没深度不应小于200mm。



不锈钢高效旋流防止器技术参数

连接法兰压力等级	1.0MPa, 1.6MPa, 2.5MPa
工作介质	直饮水、饮用水水、污水、油、弱酸或者弱碱介质
工作温度	0~120°C
材质	06Cr19Ni10(304), 材质成分符合GB/T20878标准
使用要求按标准	GB50974, 同时符合欧盟标准BS EN2845的标准设计要求
法兰连接尺寸按标准	GB/T17241.6同时符合B.S.4504GB
符合标准	GB/T17219的卫生要求

旋流防止器安装尺寸

旋流防止器的尺寸按照EN,12845,条例9.3,图所示(单位mm)											
旋流防止器立装											
管道公称直径(DN)	65	80	100	150	200	250	300	350	400	450	500
旋流防止器顶板宽带A	220	220	234	623	827	1030	1232	1232	1232	1232	1232
旋流防止器顶板宽带B	44	44	54	79	101	130	155	191	191	209	209
旋流防止器位置C	300	310	412	512	614	715	816	816	816	816	816
水箱允许最低水位D(旋流防止器)	100	100	100	100	100	100	100	100	100	100	100

1. 口径:DN25-DN500(现有的产品,规格可拓展)。
2. 安装方式:可正装(吸水水箱)也可以倒装(高位水箱)。
3. 安装要求:旋流防止器的外缘与水池池壁应至少留有0.3d的间隙,d为吸水管到的公称尺寸。
4. 性能要求:在缺水过程中,水位下降为水位X时,水池页面应无漩涡产生。
5. 材质要求:奥氏体不锈钢材质(304)。
6. 适用范围:适用于化工、能源、消防、水工程等领域。

消防超声波流量计/电磁流量计

消防超声波流量计

消防超声波流量计简介

超低功耗设计,功耗小于0.00055W

电池供电可连续工作6-10年

采用超声波传感器,无机械转动部分,10年免维护设计

双向流量均可测量、测量管段模具铸造,保证无泄漏

测量精度±1%、±2%、±3%可选

二、消防管道式超声波流量计技术参数

测量原理:超声波时差原理,采用低电压多脉冲发射电路,双平衡抑制噪声接收电路。

测量介质:水及其它液体,悬浮物含量<10g/l,粒径<1mm,液体充满管道。

管径范围:DN15-1000mm全系列不同管径用户可选

管段长度:按普通水表规格尺寸设计

测量周期:默认3秒,1~31秒用户可选

适用温度:环境温度-40°C~80°C(LCD显示器-25°C~60°C)

重复性精度:优于±0.5%

传感器:高温耐磨陶瓷传感器,适用介质流体温度-40°C~160°C

防护等级:IP68,压铸铝仪表壳,水下2米正常工作

接口输出:RS232、RS485标准配置,4-20mA、M-BUS、GPRS、CDMA、GSM短消息可选配。

供电方式:单节3.6V锂电池可工作6年,选配电池可工作十年以上,电压2.6V时工作正常工作;有源4-20mA供电(两线制),无需电池即可正常工作;RS232输出时主机切电工作,无需电池即可正常工作;RS485输出时需要外加5V电源,无需电池即可正常工作。

三、消防管道式超声波流量计特点

适用液体介质:水、酸碱液、油类等单一均匀稳定的流体,浊度小于

10000ppm,粒径小于1mm

适用介质温度:温度0°C~160°C功能:正反向双向计量,可计量正、

负、净累积流量;压力:≤1.6MPa

环境温/湿度:主机-30°C~+80°C;传感器-40°C~+160°C,传感器可浸

入液体中

流速范围:0~±30m/s

精度等级:优于1%

重复性:优于0.5%

1. 结构紧凑、坚固,精度高。
2. 有4-20mA或0~20m输出,可带RS-232通讯或RS-485通讯。
3. OTC输出正、负、净累积流量脉冲信号或瞬时流量频率信号。
4. 有声音报警提示功能,自动记忆前64日,前6个月,前5年的累积流量。
5. 可输入5路模拟电流信号。

管道式超声波流量计采用超声波时差原理来计量圆管内液体的流量。富士达公司生产的超声波水表采用工业级电子元件,依靠电池供电,无机械转动,无磨损,无压力损失,是一种全电子的工业用水表。超声波水表具有精度高、可靠性好、价格低、使用寿命长等优点。可完全替代其它类型的水表。



电磁流量计



LD系列电磁流量计测量原理是法拉第电磁感应定律,传感器主要组成部分是:测量管、电极、励磁线圈、铁芯与磁轭壳体。

电磁流量计主要用于测量封闭管道中的导电液体和浆液中的体积流量。包括酸、碱、盐等强腐蚀性的液体。电磁流量计广泛应用于石油化工、钢铁冶金、给水排水、水利灌溉、水处理、环保污水总量控制、造纸、医药、食品等工、农业部门的生产工艺过程流量测量和控制;适用于导电液体的总量计量LD系列防爆型流量计仪表选型

量程范围确认

一般工业用防爆型流量计被测介质流速以2~4m/s为宜,在特殊情况下,最低流速应不小于0.2m/s,最高应不大于8m/s。若介质中含有固体颗粒,常用流速应小于3m/s,防止衬里和电极的过分磨损;对于粘滞流体,流速可选择大于2m/s,较大的流速有助于自动消除电极上附着的粘滞物的作用,有利于提高测量精度。在量程Q已确定的条件下,即可根据上述流速V的范围决定流量计口径D的大小,其值由下式

计算:Q=πD²V/4 Q:流量(m³/h) D:管道内径 V:流速(m/h)防爆型流量计的量程Q应大于预计的最大流量值,而正常的流量值以稍大于流量计满量程刻度的50为宜。

Double Flange Expansion Joint

Product Overview

In fluid transportation pipelines, issues such as installation and maintenance difficulties, expansion and contraction due to temperature differences over long distances, and pipeline deflection caused by foundation settlement have long troubled engineering designers and operators. The double flange loose sleeve compensation joint features a compact structure, rational design, reliable sealing, and convenient installation and removal. It compensates for axial displacement of pipelines within a certain range, transmits axial thrust and tension, and functions to adjust maximum expansion and prevent pipe joint loosening. It can replace expansion joints like U-shaped pipes and bellows, offering an ideal solution for pipeline installation and expansion challenges.

Features:

- Compact structure
- Shorter structural length, saving space for pipeline installation and maintenance
- Flexible extension and retraction
- Low伸缩 resistance, adjustable maximum allowable伸缩量
- Safety limit stop
- Limit device prevents pipeline loosening and leakage
- Reliable sealing
- "O"-type sealing ring, easily adjustable to ensure zero leakage
- Easy loading and unloading
- Stud connection, simple structure, easy installation and maintenance
- Surface protection
- Special coating treatment on inner and outer surfaces for hygiene and corrosion resistance

Technical Parameters:

- Material used: Ductile iron, Carbon steel
- Size range: DN50mm~DN1800mm
- Pressure rating: 0.6MPa~1.6MPa
- Temperature range: -29°C ~ 100°C
- Applicable media: Water, Sludge, Oil products, etc.



Material:

Serial Number	Name	Material
1	Set Plate	Ductile Iron
2	Sealing Ring	NBR
3	Cover	Ductile iron
4	Stud, nut	Carbon steel, galvanized
5	Nozzle	Ductile iron

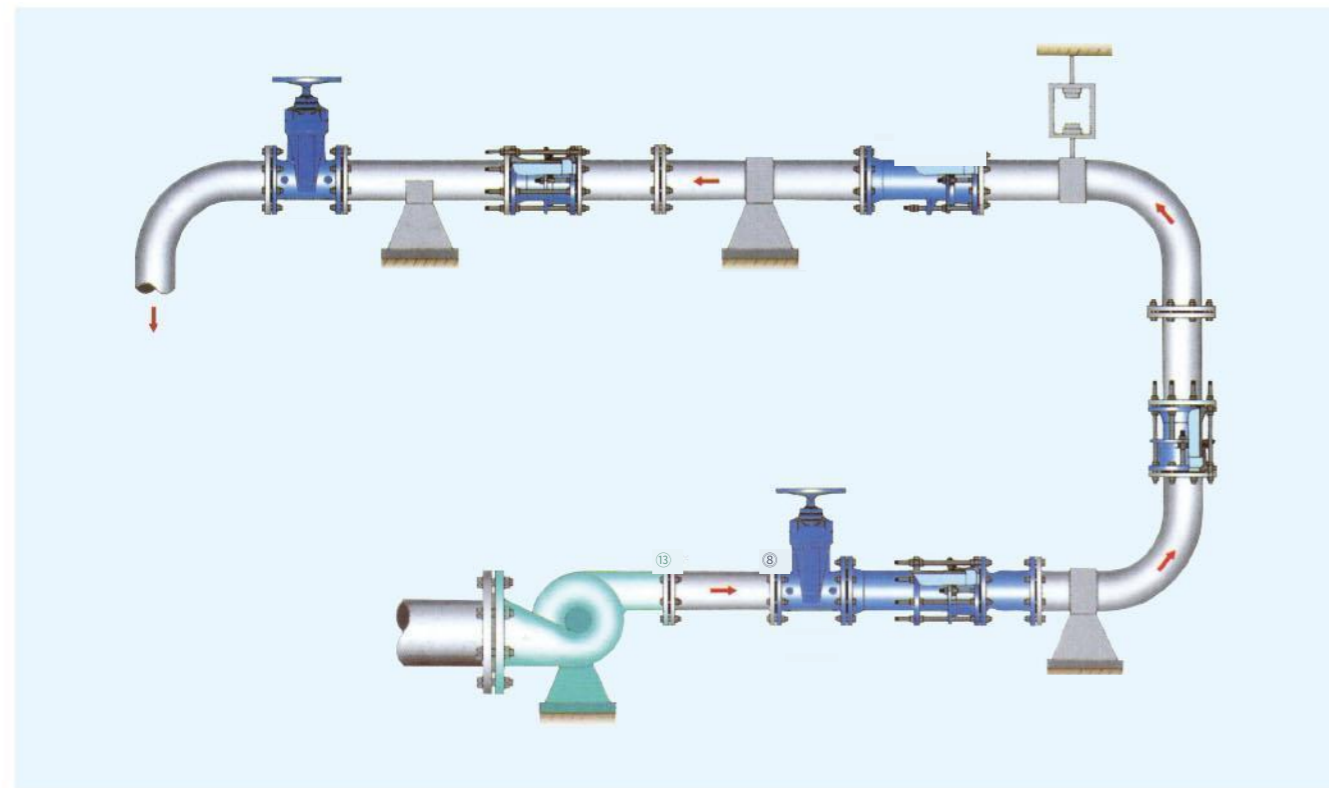

Vacuum Breaker Valve

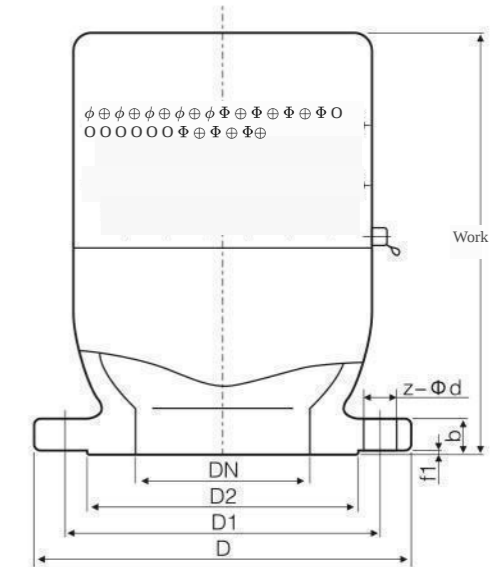

Features

- The vacuum breaker valve acts on the rear end of the turbine; when the vacuum degree reaches the valve's set value range, the valve begins to open, supplying air into the pipe.
- This valve employs stainless steel brazing technology to ensure effective sealing.
- The vacuum degree is adjusted according to the valve's initial opening during factory setup (please specify for special requirements).

Main overall dimensions

Nominal diameter DN	1.6MPa						
	D	D1	D2	z-Φd	b	f1	H
15	95	65	45	4-14	14	2	110
20	105	75	55	4-14	16	2	130
25	115	85	65	4-14	16	2	150
32	135	100	78	4-18	18	2	180
40	145	110	85	4-18	18	3	200
50	160	125	100	4-18	20	3	221
65	180	145	120	4-18	18	3	230
80	195	160	135	4-18	22	3	245
100	215	180	155	8-18	22	3	253
125	245	210	185	8-18	24	3	280
150	280	240	210	8-23	24	3	329
200	335	295	265	8-23	26	3	377
250	390	525	320	12-23	28	3	440
400	580	525	495				960
500	705	650	720				1180
600	840	770	720				1390

JR Type Metal Hose

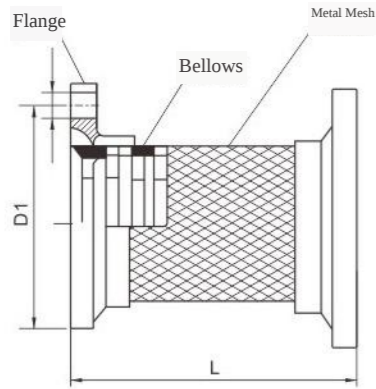

Performance Characteristics:

Corrugated metal hoses are a high-quality flexible pipeline in modern industrial piping systems. Made entirely of austenitic stainless steel, they ensure excellent flexibility, fatigue resistance, high and low temperature tolerance, corrosion resistance, and many other characteristics. The elasticity of the corrugated profile allows it to easily absorb various motion deformations and cyclic loads, especially compensating for large displacements in piping systems. Its lifespan is significantly longer compared to other hoses, offering high comprehensive economic benefits. These hoses are suitable for conveying pipes requiring full flexibility and for piping in vibration-prone locations, applicable to steam, gas, air, petroleum, chemical, and pharmaceutical industries.

Metal Hose Marking Method

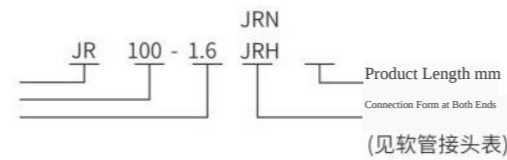

Design temperature: -20°C to +400°C Product code: JR Model designation: JR

Nominal diameter mm	Inner diameter mm	Outer diameter mm		Minimum bending radius mm		Maximum working pressure MPa	
		Bellows	With one layer of mesh sleeve	Static	Dynamic	One layer of mesh sleeve	Two layers of mesh sleeve
8	8.8	13.2	14.4	50	110	15	20
10	11.7	16.5	17.7	65	145	15	20
15	13.5	19.5	21.1	80	180	15	20
20	20	27	28.6	120	270	10	15
25	27	34.5	36.1	160	360	6.3	10
32	32	40	41.6	175	400	4.0	6.3
40	39.6	52	53.6	225	510	4.0	6.3
50	49.7	62	63.6	280	640	3.0	5.0
65	61.2	80.2	81.8	410	915	3.0	5.0
80	79	96.3	97.9	486	1030	3.0	5.0
100	101.2	119.6	121.2	610	1340	2.5	4.0
125	124.1	145.3	146.9	700	1540	2.5	4.0
150	149.4	180.8	182.4	810	1780	2.5	4.0
200	176	240	243.2	1000	2000	2.5	4.0
250	248	290	294	1250	2500	2.5	4.0
300	298	350	354	1500	3000	1.6	2.5
350	347.6	400	404.8	1750	3500	1.6	2.5
400	397.6	460	464.8	2000	4000	1.6	2.5

RFJD/S Type Single and Double Sphere Flexible Rubber Joint

Product Overview

This product is manufactured by our company using the new air-blown mold process, consisting of a composite sphere of inner rubber layer, reinforcement layer, middle rubber layer, outer rubber layer, and loose-sleeve forged low-carbon steel flanges. It features high pressure resistance, excellent elasticity, large displacement, effective vibration absorption and noise reduction, and easy installation. It is widely applicable to pipeline systems in water supply and drainage, HVAC, fire protection, compressors, papermaking, pharmaceuticals, ships, water pumps, fans, and more.

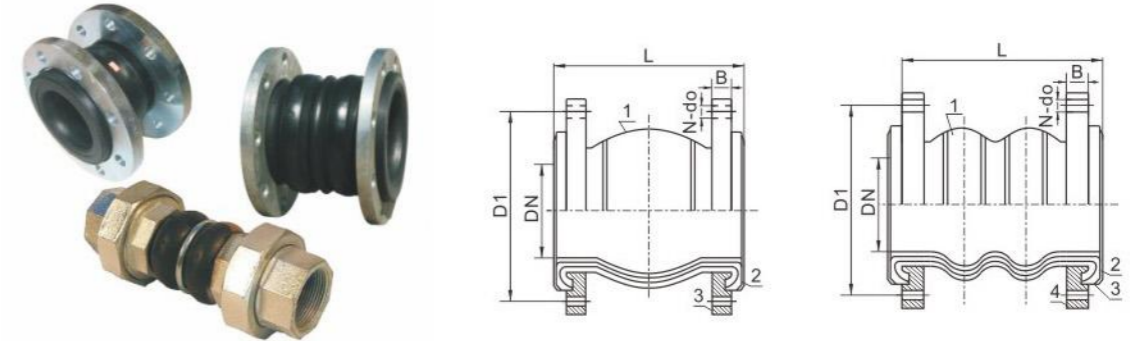

Main Data

Item Parameter Grade	0.25 MPa	0.6 MPa	1.0 MPa	1.6 MPa	2.5 MPa
Universal diameter (mm)	1200-2800	350-1200	32-600	32-300	32-150
Matching flange MPa (kg.f/cm ²)	0.6(6)	0.6(6)	1.0(10)	1.6(16)	2.5(25)
Working pressure MPa (kg.f/cm ²)	0.25(2.5)	0.6(0.6)	1.0(10)	1.6(16)	2.5(25)
Burst pressure MPa (kg.f/cm ²)	0.75(7.5)	1.8(1.8)	3.0(30)	4.8(48)	7.5(75)
Vacuum degree KPa (mmHg)	19.9(150)	33.2(250)	53.5(400)	86.7(650)	100(750)

Main component materials

Serial number	Location	Material
1	Main body	Polar rubber
2	Lining	Nylon cord
3	Flange	Low carbon steel

Main data (single sphere)

DNmm	Length Lmm	Flange thickness bmm	Number of bolts n	Bolt hole diameter dmm	Bolt hole pitch circle diameter D1mm	Axial displacement mm		Lateral displacement mm	Deflection angle (α1+α2)
						Elongation	Compression		
32	95	14	4	18	100	6	9	9	15°
40	95	16	4	18	110	6	10	9	15°
50	105	16	4	18	125	7	10	10	15°
65	115	18	4	18	145	7	13	11	15°
80	135	18	8	18	160	8	15	12	15°
100	150	20	8	18	180	10	19	13	15°
125	165	22	8	18	210	12	19	13	15°
150	180	22	8	22	240	12	20	14	15°
200	200	22	8	22	295	16	25	22	15°
250	230	26	12	22	350	16	25	22	15°
300	245	26	12	22	400	16	25	22	15°
350	255	26	16	22	460	16	25	22	15°
400	255	28	16	26	515	16	25	22	15°
450	255	28	20	26	565	16	25	22	15°
500	255	30	20	26	620	16	25	22	15°
600	260	34	20	26	725	16	25	22	15°
700	260	34	24	26	810	16	25	22	15°
800	260	34	24	30	920	16	25	22	15°
900	260	34	24	30	1020	16	25	22	10°
1000	260	34	28	30	1120	16	25	22	10°

Main Data (Double Sphere)

DNmm	Length L mm	Flange thickness b mm	Bolt Number n	Bolt hole diameter d mm	Bolt hole pitch circle diameter D1 mm	Axial displacement mm		Lateral displacement mm	Deflection angle (α1+α2)
						Elongation	Compression		
50	165	16	4	17.5	125	30	50	45	40°
65	175	18	4	17.5	145	30	50	45	40°
80	175	18	8	17.5	160	30	50	45	40°
100	225	18	8	17.5	180	35	50	40	35°
125	225	20	8	17.5	210	35	50	40	35°
150	225	22	8	22	240	35	50	40	35°
200	325	22	8	22	295	35	60	35	30°
250	325	24	12	22	350	35	60	35	30°
300	325	24	12	22	400	35	60	35	30°

Stainless steel valve

Stainless steel one-piece ball valve

Model	Q11F
Nominal diameter	DN6~DN100
Nominal pressure	6.5MPa
Applicable Temperature	120°C
Main Material	Threaded ends can be manufactured to BSPT, NPT, DIN2999



Stainless Steel Two-Piece Ball Valve

Model	Q11F
Nominal Diameter	DN6~DN100
Nominal Pressure	6.5MPa
Applicable Temperature	120°C
Main Material	Threaded ends can be manufactured to BSPT, NPT, DIN2999



Stainless steel three-piece ball valve

Model	Q11F
Nominal diameter	DN6~DN100
Nominal pressure	6.5MPa
Applicable temperature	120°C
Main Materials	Threaded ends can be manufactured to BSPT, NPT, DIN2999; optional threaded or socket weld ports, butt weld, optional with locking handle.



Stainless Steel Filter

Model	GL11W
Nominal Diameter	DN15-DN100
Nominal pressure	2.5MPa
Applicable temperature	-40 ~ 232°C
Main material	CF8M



Stainless steel valve



Stainless steel globe valve

Model	J11W
Nominal Diameter	DN6~DN50
Nominal Pressure	1.6MPa~6.4MPa
Applicable Temperature	-40~180°C
Applicable Media	Water, Oil, Gas, Nitric Acid, Acetic Acid



Stainless Steel Gate Valve

Model	Z15W
Nominal Diameter	DN15~DN100
Nominal Pressure	1.6MPa~6.4MPa
Applicable Temperature	-40~180°C
Applicable Medium	Water, Oil Products, Gas, Nitric Acid Series, Acetic Acid Series



Stainless steel tee-type ball valve

Model	Q11F
Nominal diameter	DN15~DN50
Nominal pressure	1.6MPa~6.4MPa
Applicable temperature	120°C
Main Materials	Threaded ends can be manufactured to BSPT, NPT, DIN2999, ISO5211 flange, with optional locking handle



Stainless Steel Check Valve

Model	H14W
Nominal Diameter	DN15-DN100
Nominal Pressure	1.6MPa~6.4MPa
Applicable Temperature	T≤180°C
Applicable Medium	Water, oils, gases, nitric acid compounds, acetic acid compounds

HVAC Series

Full Bore Ball Valve



Check Ball Valve



Long Handle Temperature Measuring Ball Valve 	Long Handle Aluminum-Plastic Ball Valve 	Long Handle Filter Ball Valve 	Male-Female Thread Ball Valve
Brass Ball Valve 	Telescopic Brass Ball Valve 	(2000) Series Ball Valve 	Brass Ball Valve
High Stem Ball Valve 	电动两通球阀 	Union Electric Ball Valve 	电动两通阀
Square Head Magnetic Locking Ball Valve 	Magnetic Locking Filter Ball Valve 	Magnetic Locking Ball Valve 	Magnetic Locking Gate Valve

HVAC Series

Engineering Gate Valves 	Expansion Brass Gate Valve 	Lockable Brass Gate Valve 	Brass Globe Valve
PP-R Stop Valve 	Balancing Valve 	Swing Check Valve 	Vertical Check Valve
Heavy-Duty Vertical Check Valve 	Brass Filter Valve 	Flange Filter 	Flange Check Valve
Flange Globe Valve 	Pressure Reducing Valve 	Flange Ball Valve 	Automatic Air Vent Valve
Pre-meter Anti-drip Ball Valve 	Magnetic Control Valve 	Gate Valve 	Ball Valve



暖通系列

角式暖气阀 	角式暖气阀 	角式暖气阀 	角式暖气阀 
角式暖气阀 	直式暖气阀 	直式暖气阀 	直式暖气阀 
角式回水阀 	角式回水阀 	直式自动温控阀 	角式自动温控阀 
三通温控阀 	三通自动温控阀 	PPR直式温控阀 	
PPR外螺纹活接头 	真空破坏器 		
		金属软管 	

剑桥宗旨与承诺

客户是企业的生命所在，没有满意的客户就没有企业的发展前途

剑桥经营宗旨

- 一、公司遵循“持续的质量改进是企业永恒的目标”的经营理念。
- 二、本公司所生产产品均严格实施和达到企业标准和国家机械部阀门标准。
- 三、本公司接到客户定单通知后，严格按照合同条款的有关规定进行发货，按照客户要求的时间，地点送达并保证产品完好无损。

剑桥十大品牌承诺

- 一、壳体壁厚达到和超过国家GB、美国ANSI等标准要求。
- 二、主体材质化学成份和力学性能达到国家规定标准要求（保存材质化验报告，提供试棒及力学性能报告）。
- 三、阀杆材质化学成份达到国家规定要求，光洁度达到国家标准要求，表面经抗蚀性氮化或调质处理，保证阀杆力学性能。
- 四、公差尺寸符合国家GB1800-1804标准要求，零部件通配互换。
- 五、阀门承压件每台都进行无损探伤检验、保证符合JB/T6440X射线检验标准、JB/T6439磁粉探伤检验标准和JB/T6903超声波检验标准。
- 六、密封阀座结构采用：分离式螺纹阀座和分离式镶嵌焊接阀座。上密封采用分离式螺纹阀座。
- 七、密封面采用等离子堆焊，硬度达到国家GB/T12234-12236标准要求，宽度超过国家标准，电站阀门密封面都经过着色探伤，检验符合JB/T6902标准要求。
- 八、整机装配前用煤油和防锈油经高压喷射清洗，试压后清除试验介质，喷上防锈油，腔清洁度达到JB/T7748标准要求，符合阀门长期储存要求。
- 九、公司如特殊原因不能按期交货，则按合同订货总金额的5%计算处罚违约金。
- 十、客户提货后在18个月内，因产品制造质量问题而导致密封试压不合格，公司保证包换、包退并自行承担运费。

殷切期待您能与
剑桥阀业集团有限公司愉快交流合作!